

## 40V Dual N-Channel Enhancement Mode MOSFET

### Description

The NP4886QR uses advanced trench technology to provide excellent  $R_{DS(ON)}$  with low gate charge.

This device is suitable for high side switch in SMPS and general purpose applications.

### General Features

- ◆  $V_{DS} = 40V$ ,  $I_D = 15A$
- ◆  $R_{DS(ON)} = 12m\Omega$  (typical) @  $V_{GS} = 10V$
- ◆  $R_{DS(ON)} = 15m\Omega$  (typical) @  $V_{GS} = 4.5V$
- ◆ Excellent gate charge x  $R_{DS(ON)}$  product(FOM)
- ◆ Very low on-resistance  $R_{DS(ON)}$
- ◆ 150 °C operating temperature
- ◆ Pb-free lead plating
- ◆ 100% UIS tested

### Application

- ◆ DC/DC Converter
- ◆ Ideal for high-frequency switching and synchronous rectification

### Package

- ◆ PDFN3\*3-8L

### Schematic diagram

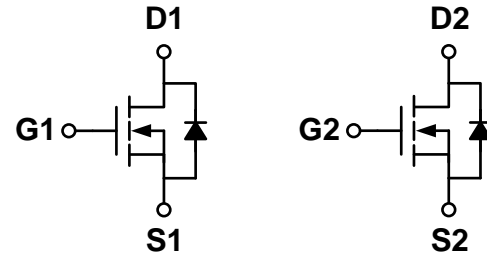

### Marking and pin assignment

PDFN3×3-8L

(Top View)

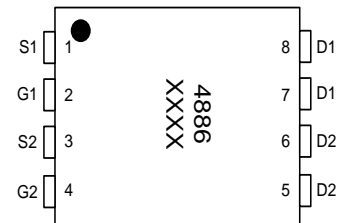

XXXX—Wafer Information

YYYY—Quality Code

### Ordering Information

Part Number	Storage Temperature	Package	Devices Per Reel
NP4886QR-G	-55°C to +150°C	PDFN3*3-8L	5000

### Absolute Maximum Ratings (TA=25°C unless otherwise noted)

parameter	symbol	limit	unit	
Drain-source voltage	$V_{DS}$	40	V	
Gate-source voltage	$V_{GS}$	±20	V	
Drain Current-Continuous (Silicon Limited)	$I_D$	$T_A = 25^\circ C$	15	A
		$T_A = 75^\circ C$	10	A
Pulsed Drain Current (Package Limited)	$I_{DM}$	40	A	
Single pulse avalanche energy (L=0.1mH)	$E_{AS}$	20	mJ	
Maximum power dissipation	$P_D$	$T_A = 25^\circ C$	2	W
		$T_A = 75^\circ C$	1.3	W

Operating junction Temperature range	T <sub>j</sub>	-55—150	°C
--------------------------------------	----------------	---------	----

**Electrical Characteristics** (TA=25°C unless otherwise noted)

Parameter	Symbol	Condition	Min	Typ	Max	Unit
<b>Static Characteristics</b>						
Drain-source breakdown voltage	BV <sub>DSS</sub>	V <sub>GS</sub> =0V, I <sub>D</sub> =250μA	40	-	-	V
Zero gate voltage drain current	I <sub>DSS</sub>	V <sub>DS</sub> =40V, V <sub>GS</sub> =0V	-	-	1	μA
		T <sub>J</sub> =85°C	-	-	5	
Gate Leakage Current	I <sub>GSS</sub>	V <sub>DS</sub> =0V, V <sub>GS</sub> =±20V	-	-	±100	nA
Gate threshold voltage	V <sub>GS(th)</sub>	V <sub>DS</sub> =V <sub>GS</sub> , I <sub>D</sub> =250μA	1	1.4	1.8	V
Drain-source on-state resistance <sup>1</sup>	R <sub>DS(ON)</sub>	V <sub>GS</sub> =10V, I <sub>D</sub> =15A	-	12	19.2	mΩ
		V <sub>GS</sub> =4.5V, I <sub>D</sub> =15A	-	15	28.8	
Forward Transconductance	g <sub>FS</sub>	V <sub>DS</sub> = 5V, I <sub>D</sub> = 12A	-	33	-	S
<b>Diode Characteristics</b>						
Diode Forward Voltage	V <sub>SD</sub>	I <sub>SD</sub> =1A, V <sub>GS</sub> =0V	-	0.82	1.1	V
Diode Continuous Forward Current	I <sub>S</sub>		-	-	15	A
Reverse Recovery Time	t <sub>rr</sub>	I <sub>F</sub> =15A,	-	30	-	ns
Reverse Recovery Charge	Q <sub>rr</sub>	dI/dt=100A/μs	-	12	-	nC
<b>Dynamic Characteristics</b>						
Gate Resistance	R <sub>G</sub>	V <sub>GS</sub> =0V, V <sub>DS</sub> =0V, f=1MHz	-	2.2	-	Ω
Input capacitance	C <sub>ISS</sub>	V <sub>GS</sub> =0V, V <sub>DS</sub> =20V f=1.0MHz	-	1166	-	pF
Output capacitance	C <sub>OSS</sub>		-	100	-	
Reverse transfer capacitance	C <sub>RSS</sub>		-	86	-	
Turn-on delay time	t <sub>D(ON)</sub>	V <sub>GS</sub> =10V, V <sub>DS</sub> =20V, R <sub>L</sub> =2Ω, R <sub>G</sub> =3Ω	-	4	-	ns
Turn-on Rise time	t <sub>r</sub>		-	3	-	
Turn-off delay time	t <sub>D(OFF)</sub>		-	15	-	
Turn-off Fall time	t <sub>f</sub>		-	2	-	
Total gate charge	Q <sub>g</sub>	V <sub>GS</sub> =10V, V <sub>DS</sub> =20V, I <sub>D</sub> =15A	-	23.5	-	nC
Gate-source charge	Q <sub>gs</sub>		-	3.5	-	
Gate-drain charge	Q <sub>gd</sub>		-	4.2	-	

**Thermal Characteristics**

Parameter	Symbol	Typ	Max	Unit
Maximum Junction-to-Ambient <sup>A</sup>	R <sub>θJA</sub>	48	68.5	°C/W
Maximum Junction-to-Ambient <sup>A</sup>		Steady-State	74	
Maximum Junction-to-Lead <sup>B</sup>	R <sub>θJC</sub>	32	40	

A: The value of R<sub>θJA</sub> is measured with the device mounted on 1in 2 FR-4 board with 2oz. Copper, in a still air environment with T<sub>A</sub>=25°C. The value in any given application depends on the user's specific board design. The current rating is based on the t ≤ 10s thermal resistance rating.

B: The  $R_{qJA}$  is the sum of the thermal impedance from junction to lead  $R_{qJL}$  and lead to ambient.

## Typical Performance Characteristics

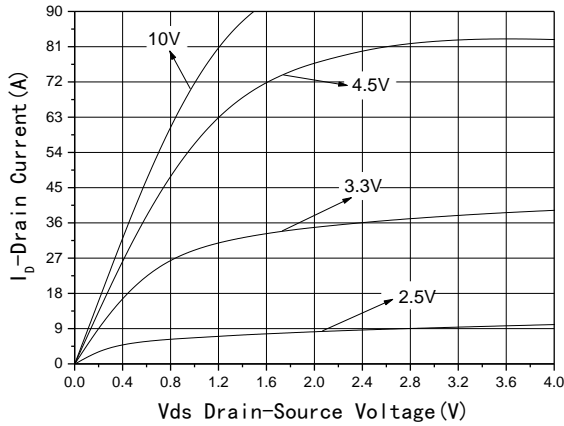

Fig1 Output Characteristics

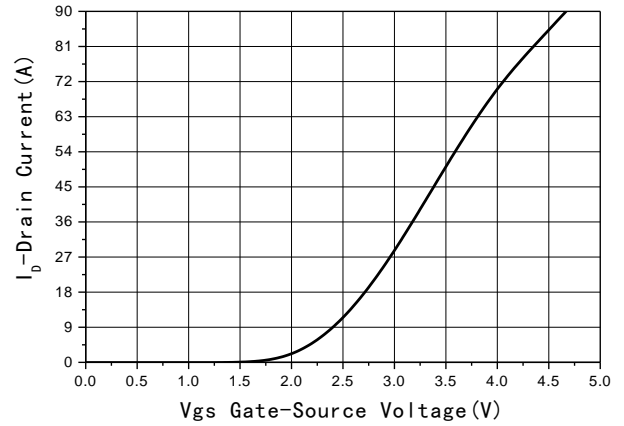

Fig2 Transfer Characteristics

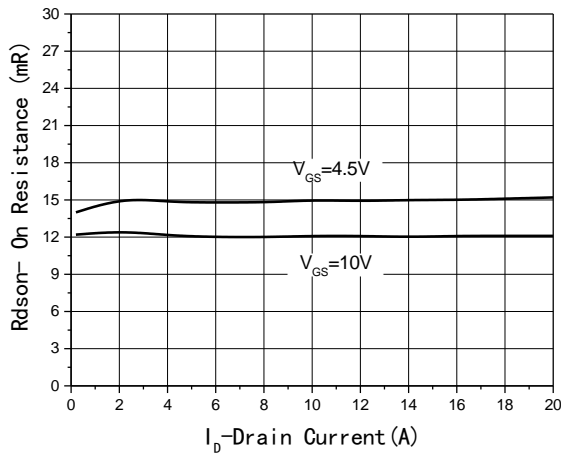

Fig3  $R_{DS(on)}$ -Drain current

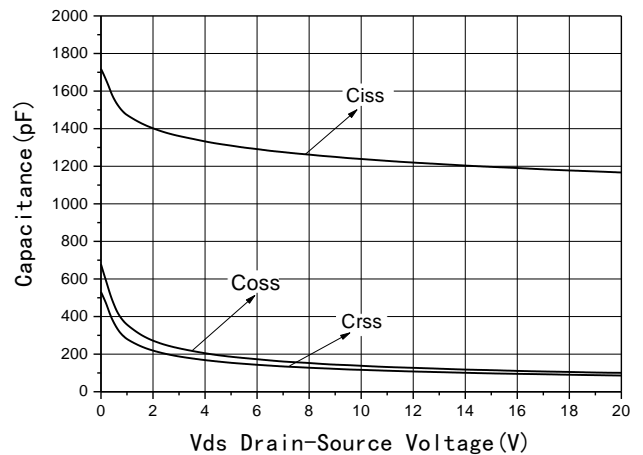

Fig4 Capacitance vs  $V_{DS}$

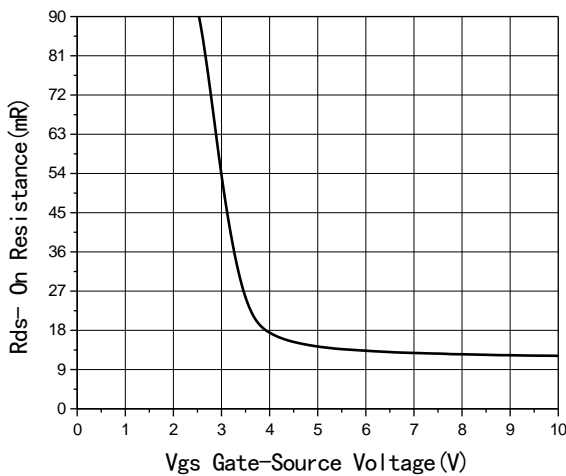

Fig5  $R_{DS(on)}$ -Gate Drain voltage

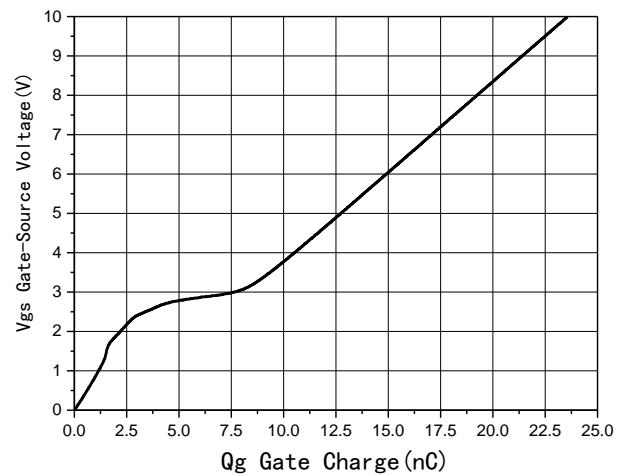

Fig6 Gate Charge

E

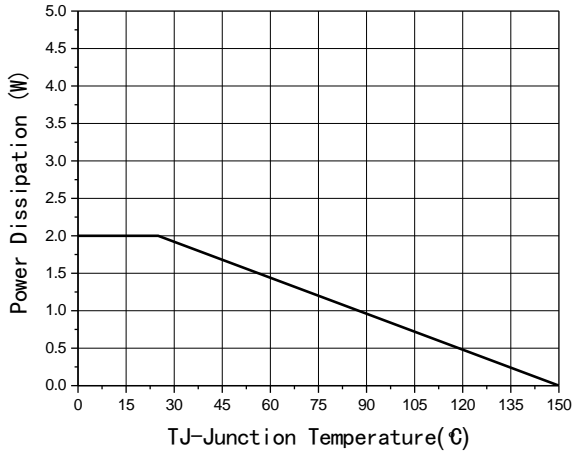

Fig7 Power De-rating

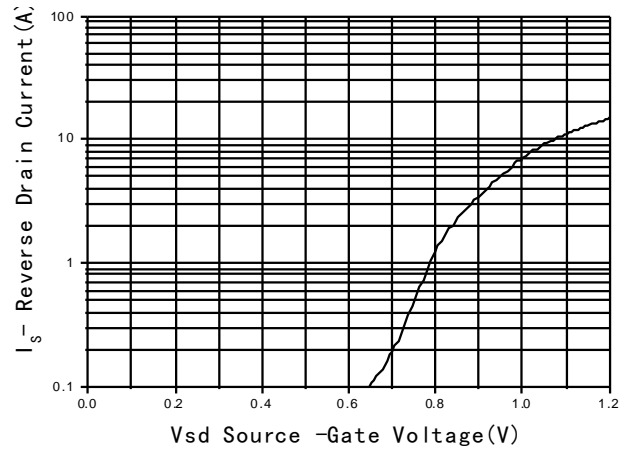
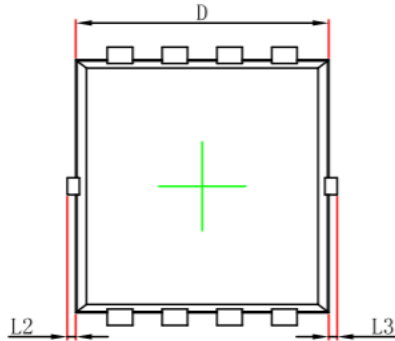

Fig8 Source-Drain Diode Forward

## Package Information

- PDFN3\*3-8L



Top View  
[顶视图]

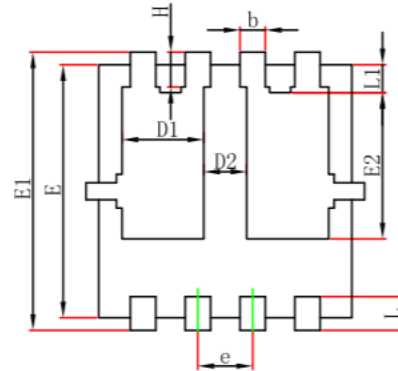

Bottom View  
[背视图]

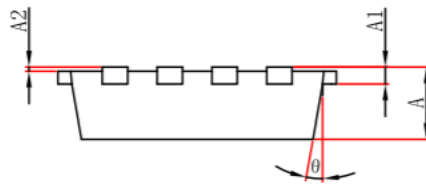

Side View  
[侧视图]

Symbol	Dimensions In Millimeters		Dimensions In Inches	
	Min.	Max.	Min.	Max.
A	0.650	0.850	0.026	0.033
A1	0.152 REF.		0.006 REF.	
A2	0~0.05		0~0.002	
D	2.900	3.100	0.114	0.122
D1	0.935	1.135	0.037	0.045
D2	0.280	0.480	0.011	0.019
E	2.900	3.100	0.114	0.122
E1	3.150	3.450	0.124	0.136
E2	1.535	1.935	0.060	0.076
b	0.200	0.400	0.008	0.016
e	0.550	0.750	0.022	0.030
L	0.300	0.500	0.012	0.020
L1	0.180	0.480	0.007	0.019
L2	0~0.100		0~0.004	
L3	0~0.100		0~0.004	
H	0.315	0.515	0.012	0.020
θ	9°	13°	9°	13°