

N And P-Channel Enhancement Mode MOSFET

Description

The NP4606BSR uses advanced trench technology to provide excellent $R_{DS(ON)}$ and low gate charge. The complementary MOSFETs may be used to form a level shifted high side switch, and for a host of other applications.

General Features

◆ N-channel:

$V_{DS} = 30V$, $I_D = 7A$

$R_{DS(ON)} = 18.5m\Omega$ (typical) @ $V_{GS} = 10V$

$R_{DS(ON)} = 32m\Omega$ (typical) @ $V_{GS} = 4.5V$

P-Channel:

$V_{DS} = -30V$, $I_D = -5A$

$R_{DS(ON)} = 42.8m\Omega$ (typical) @ $V_{GS} = -10V$

$R_{DS(ON)} = 56.6m\Omega$ (typical) @ $V_{GS} = -4.5V$

- ◆ Excellent gate charge x $R_{DS(ON)}$ product(FOM)
- ◆ Very low on-resistance $R_{DS(ON)}$
- ◆ 150 °C operating temperature
- ◆ Pb-free lead plating
- ◆ 100% UIS tested



Application

- ◆ DC/DC Converter
- ◆ Ideal for high-frequency switching and synchronous rectification

Schematic diagram

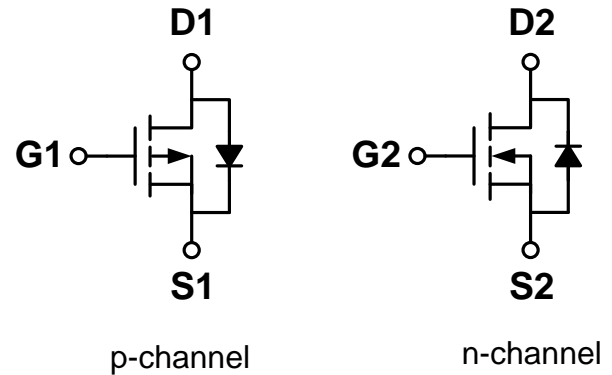

Marking and pin assignment

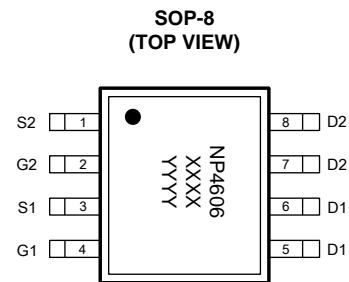

XXXX—Wafer Information

YYYY—Quality Code

Package

SOP-8

Ordering Information

Part Number	Storage Temperature	Package	Devices Per Reel
NP4606BSR-G	-55°C to +150°C	SOP-8	4000

Absolute Maximum Ratings (TA=25°C unless otherwise noted)

Parameter	Symbol	Limit		Unit
		N	P	
Drain-source voltage	V_{DS}	30	-30	V
Gate-source voltage	V_{GS}	±20	±20	V
Maximum power dissipation	P_D	2.0	2.0	W

Operating junction Temperature range		T_j	-55—150	-55—150	°C
Drain Current-Continuous (Silicon Limited)	$T_A=25^\circ\text{C}$	I_D	7	-5	A
	$T_A=75^\circ\text{C}$		5	-3	
Pulsed Drain Current (Package Limited)		I_{DM}	30	-30	A
Avalanche Current ^C		I_{AS}, I_{AR}	10	18	A
Avalanche energy $L=0.1\text{mH}^C$		E_{AS}, E_{AR}	5	26	mJ
Power Dissipation ^B	$T_A=25^\circ\text{C}$	P_D	2	2	W
	$T_A=75^\circ\text{C}$		1.3	1.3	
Junction and Storage Temperature Range		T_J, T_{STG}	-55—150		°C

N-Channel Electrical Characteristics ($T_J=25^\circ\text{C}$ unless otherwise noted)

Parameter	Symbol	Condition	Min	Typ	Max	Unit
OFF Characteristics						
Drain-source breakdown voltage	BV_{DSS}	$V_{GS}=0V, I_D=250\mu\text{A}$	30	-	-	V
Zero gate voltage drain current	I_{DSS}	$V_{DS}=30V, V_{GS}=0V$	-	-	1	μA
Gate-body leakage	I_{GSS}	$V_{DS}=0V, V_{GS}=\pm 20V$	-	-	± 100	nA
ON Characteristics						
Gate threshold voltage	$V_{GS(th)}$	$V_{DS}=V_{GS}, I_D=250\mu\text{A}$	1.0	1.4	2.5	V
Drain-source on-state resistance	$R_{DS(ON)}$	$V_{GS}=10V, I_D=7A$	-	18.5	22	m Ω
		$V_{GS}=4.5V, I_D=7A$	-	32	37	
Forward transconductance	g_{fs}	$V_{DS}=5V, I_D=7A$	-	15	-	S
Dynamic Characteristics						
Input capacitance	C_{ISS}	$V_{DS}=15V, V_{GS}=0V$ $f=1.0\text{MHz}$	-	442	-	pF
Output capacitance	C_{OSS}		-	59	-	
Reverse transfer capacitance	C_{RSS}		-	50	-	
Gate resistance	R_g	$V_{GS}=0V, V_{DS}=0V,$ $f=1.0\text{MHz}$	-	3.3	4.9	Ω
Switching Characteristics						
Turn-on delay time	$t_{D(ON)}$	$V_{DS}=15V$ $V_{GS}=10V$ $R_L=2.5\Omega$ $R_{GEN}=3\Omega$	-	4.5	-	ns
Rise time	t_r		-	2.5	-	
Turn-off delay time	$t_{D(OFF)}$		-	14.5	-	
Fall time	t_f		-	3.5	-	
Total gate charge	Q_g	$V_{DS}=15V, I_D=10A$ $V_{GS}=10V$	-	9.5	-	nC
Gate-source charge	Q_{gs}		-	2.2	-	
Gate-drain charge	Q_{gd}		-	1.5	-	

Thermal Characteristics

Thermal Resistance junction-to ambient	$R_{th JA}$	100	°C/W
--	-------------	-----	------

N-Channel: Typical Electrical And Thermal Characteristics

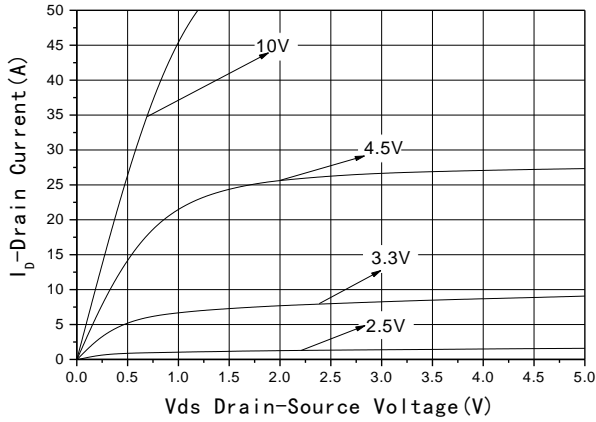

Fig1 Output Characteristics

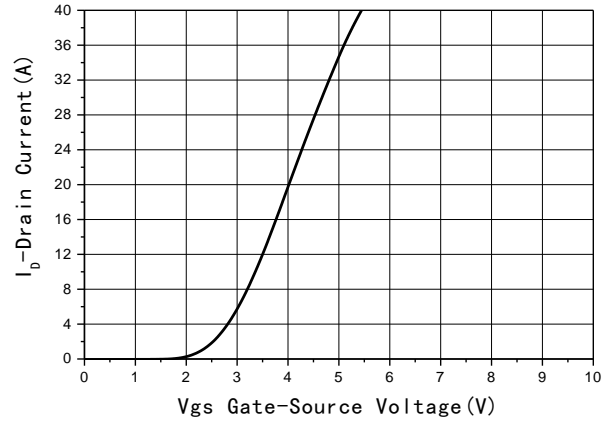

Fig2 Transfer Characteristics

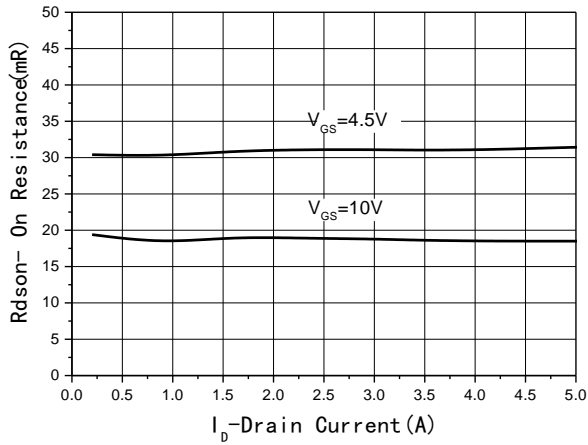

Fig3 $R_{DS(on)}$ -Drain current

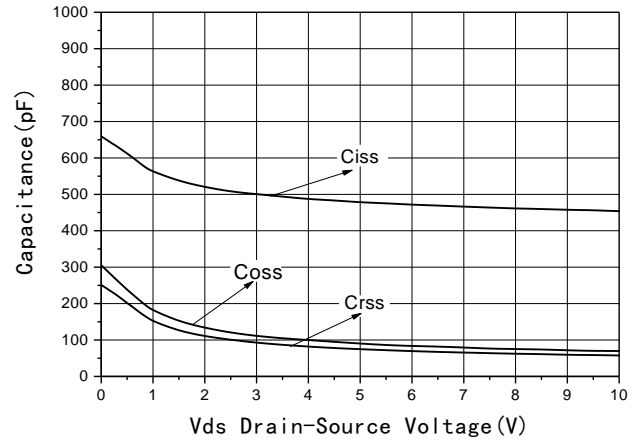

Fig4 Capacitance vs V_{DS}

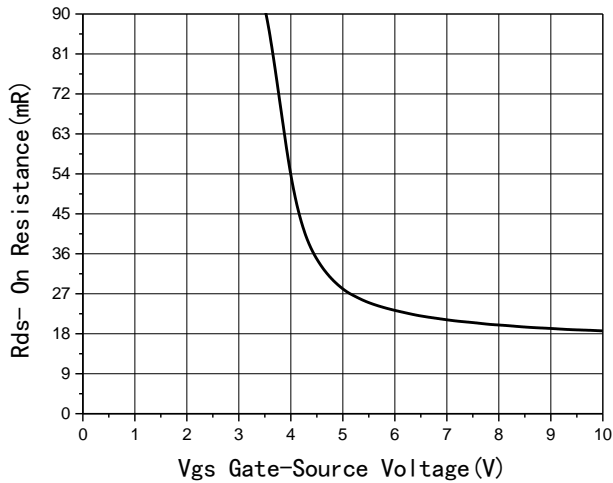

Fig5 $R_{DS(on)}$ -Gate Drain voltage

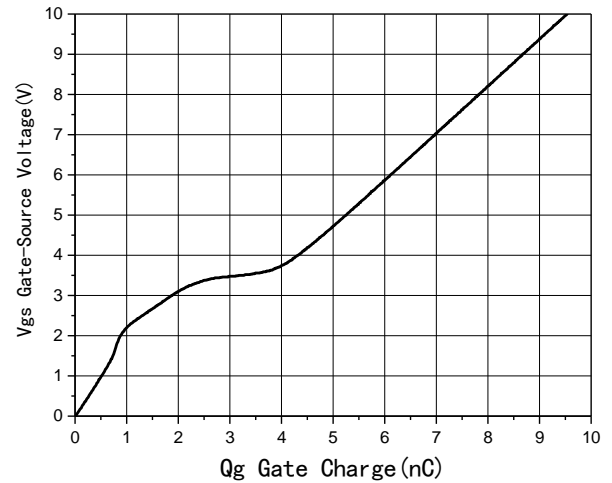

Fig6 Gate Charge

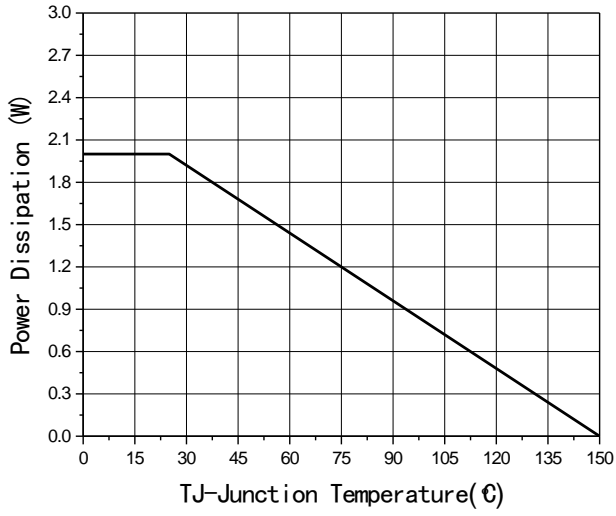

Fig7 Power De-rating

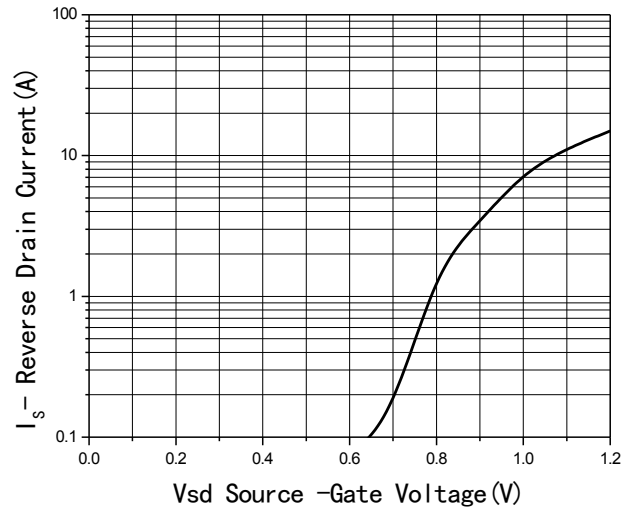

Fig8 Source-Drain Diode Forward

P-Channel Electrical Characteristics ($T_J=25^\circ\text{C}$ unless otherwise noted)

Parameter	Symbol	Condition	Min	Typ	Max	Unit
OFF Characteristics						
Drain-source breakdown voltage	BV_{DSS}	$V_{GS}=0V, I_D=-250\mu A$	-30	-	-	V
Zero gate voltage drain current	I_{DSS}	$V_{DS}=-30V, V_{GS}=0V$	-	-	-1	μA
Gate-body leakage	I_{GSS}	$V_{DS}=0V, V_{GS}=\pm 20V$	-	-	± 100	nA
ON Characteristics						
Gate threshold voltage	$V_{GS(th)}$	$V_{DS}=V_{GS}, I_D=-250\mu A$	-0.8	-1.32	-2	V
Drain-source on-state resistance	$R_{DS(on)}$	$V_{GS}=-10V, I_D=-5A$	-	42.8	53	m Ω
		$V_{GS}=-4.5V, I_D=-5A$	-	56.6	80	
Forward transconductance	gfs	$V_{DS}=-5V, I_D=-5A$	-	18	-	S
Dynamic Characteristics						
Input capacitance	C_{ISS}	$V_{DS}=-15V, V_{GS}=0V$ $f=1.0\text{MHz}$	-	567	-	pF
Output capacitance	C_{OSS}		-	63	-	
Reverse transfer capacitance	C_{RSS}		-	55	-	
Gate resistance	R_g	$V_{GS}=0V, V_{DS}=0V,$ $f=1.0\text{MHz}$	-	3.2	5	Ω
Switching Characteristics						
Turn-on delay time	$t_{D(on)}$	$V_{DS}=-15V$ $V_{GS}=-10V$ $R_L=2.3\Omega$ $R_{GEN}=3\Omega$	-	8	-	ns
Rise time	tr		-	6	-	
Turn-off delay time	$t_{D(off)}$		-	17	-	
Fall time	tf		-	5	-	
Total gate charge	Qg	$V_{DS}=-15V, I_D=-10A$ $V_{GS}=-10V$	-	12.6	-	nC
Gate-source charge	Qgs		-	2	-	
Gate-drain charge	Qgd		-	2.1	-	

P-Channel: Typical Electrical And Thermal Characteristics

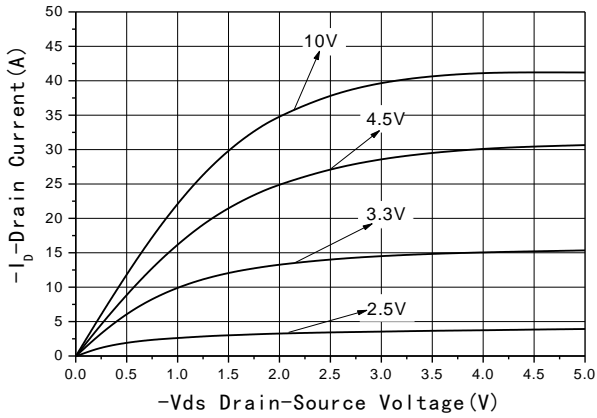

Fig1 Output Characteristics

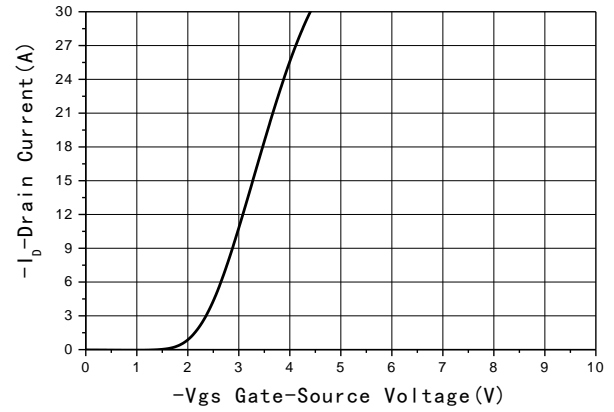

Fig2 Transfer Characteristics

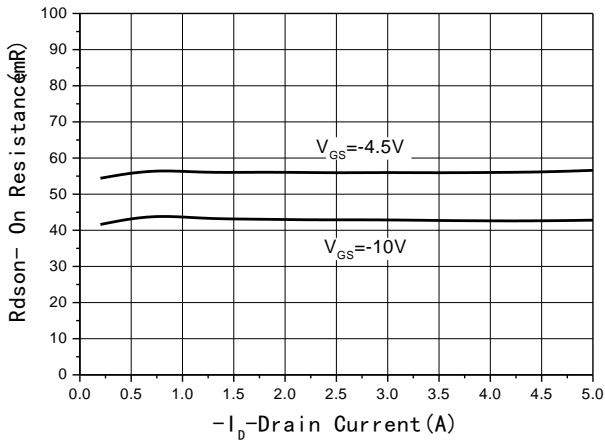

Fig3 R_{DS(on)}-Drain current

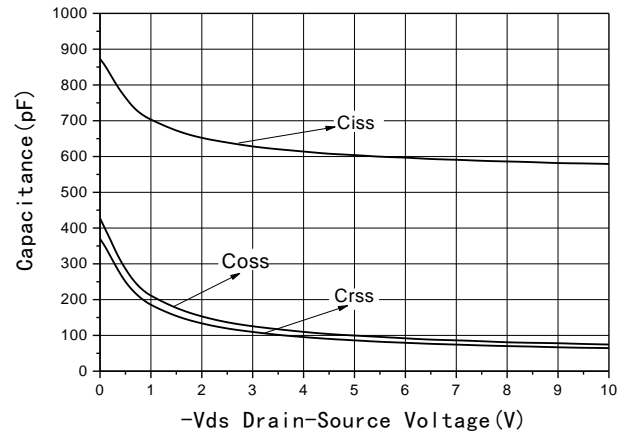

Fig4 Capacitance vs V_{DS}

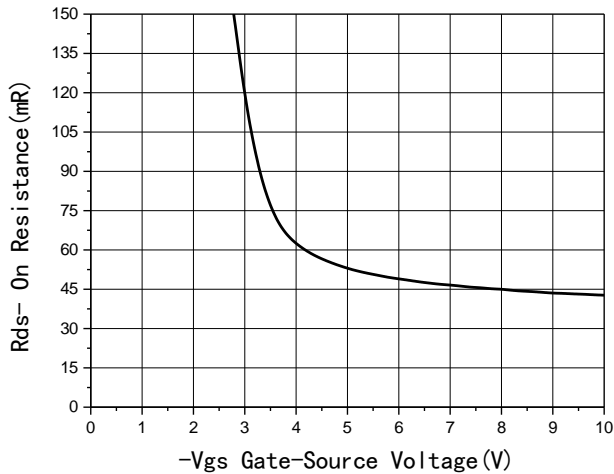

Fig5 R_{DS(on)}-Gate Drain voltage

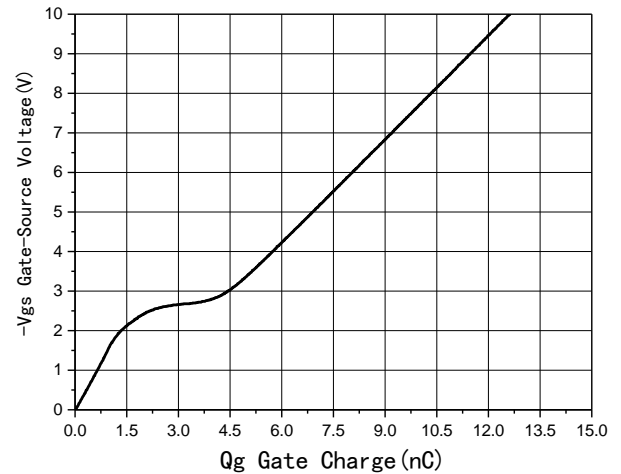

Fig6 Gate Charge

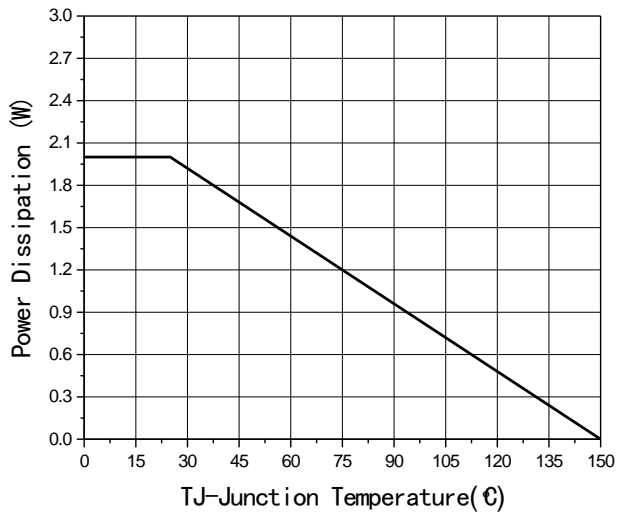

Fig7 Power De-rating

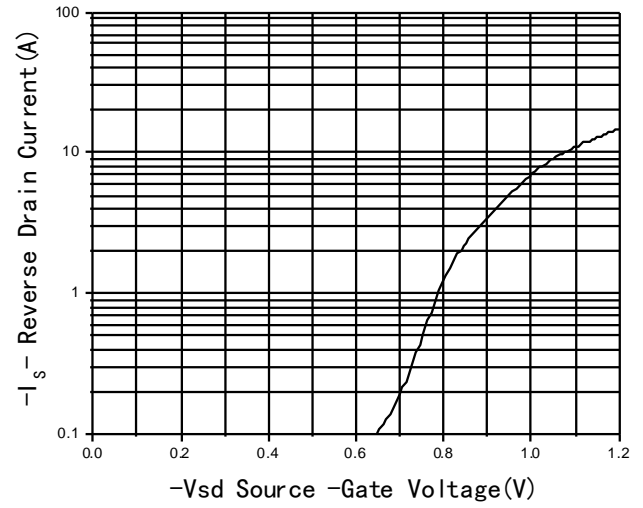
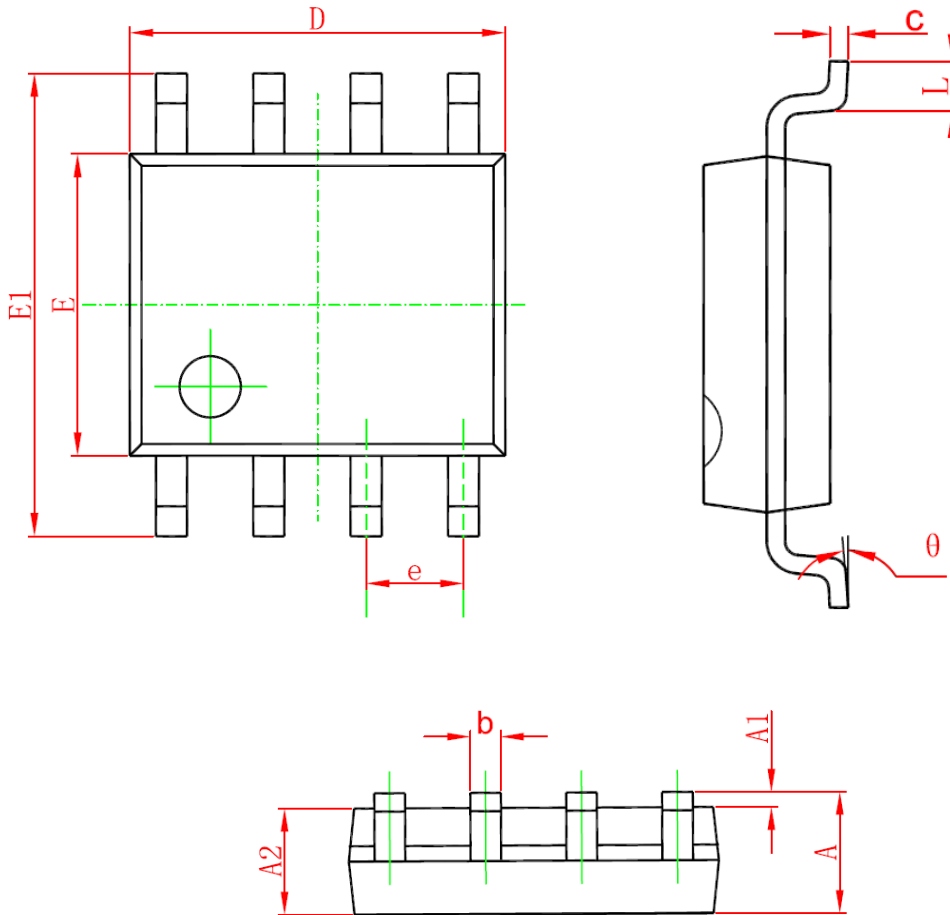

Fig8 Source-Drain Diode Forward

Package Information

- SOP-8



Symbol	Dimensions In Millimeters		Dimensions In Inches	
	Min	Max	Min	Max
A	1.350	1.750	0.053	0.069
A1	0.100	0.250	0.004	0.010
A2	1.350	1.550	0.053	0.061
b	0.330	0.510	0.013	0.020
c	0.170	0.250	0.006	0.010
D	4.700	5.100	0.185	0.200
E	3.800	4.000	0.150	0.157
E1	5.800	6.200	0.228	0.244
e	1.270 (BSC)		0.050 (BSC)	
L	0.400	1.270	0.016	0.050
θ	0°	8°	0°	8°

Recommended Minimum Pads

- SOP-8

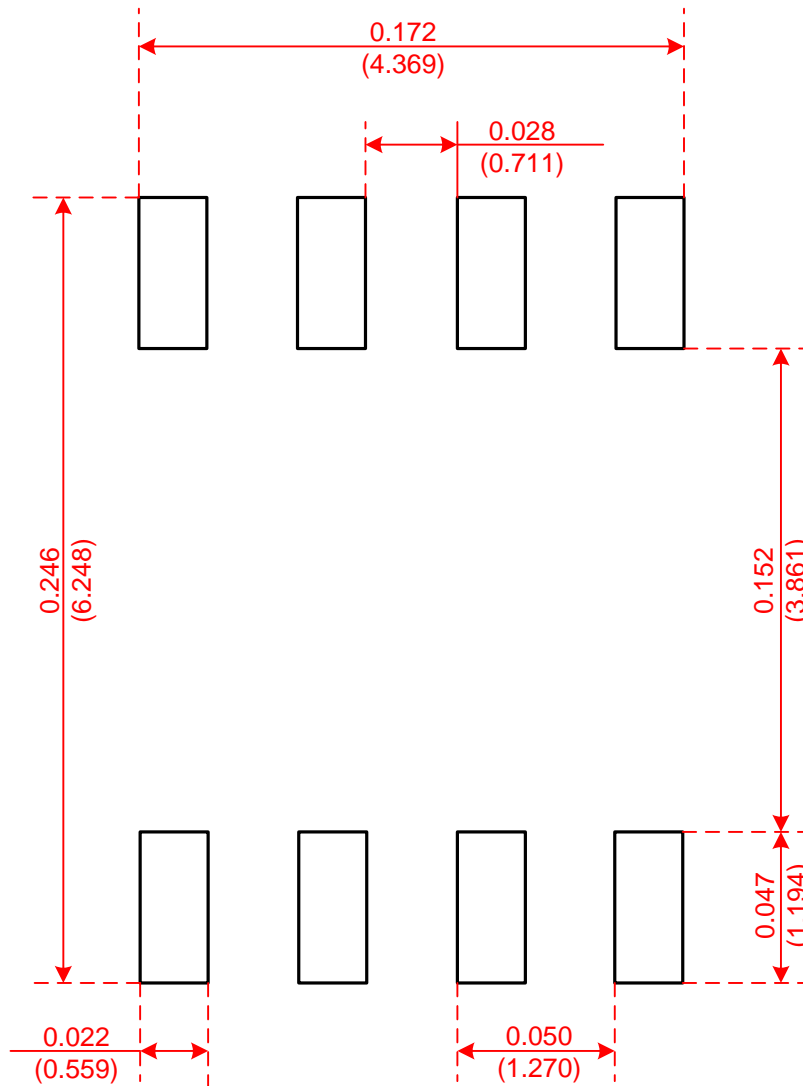

Recommended Minimum Pads
Dimensions in Inches/(mm)