

RoHS Compliant

MESSRS. : _____

AGENT : _____

**SPECIFICATION
OF
PYROELECTRIC PASSIVE
INFRARED SENSOR**

MODEL NO. : SFG223-711

PART NO. : _____

 **NIPPON CERAMIC CO., LTD.**

176-17 Hirooka, Tottori-shi, 689-1193 JAPAN
TEL : +81-857-53-4666 FAX : +81-857-53-3532

APPROVED BY	CHECKED BY	DRAWN BY

MODEL NO. : SFG223-711	DRAWING NO.	REV :	PAGE	 NIPPON CERAMIC CO., LTD.
PART NO. :		A	1 / 9	

Scope

This specification describes a pyroelectric passive infrared sensor supplied by NIPPON CERAMIC CO.,LTD.

Type of sensor

Balanced differential(series opposed type.)

Physical configuration

- 1) Appearance :
Should have no outstanding scratch, dirt and rust.
- 2) Dimensions :
See Fig.1.
- 3) Code :
Lot number is marked on top surface of detector.
To show last one digit of the A.D. year and week of the year of a inspection completion,
NicerA Identification code.

Example : 0 26 B

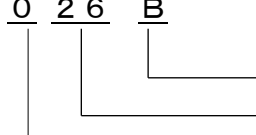

NicerA Identification code
26th week
Year 2020

【Model number】

"SFG" is marked.

Electrical characteristics (at 25 (+/-) 5 degC)

- 1) Signal output : Min. 3.0 Vp-p (Typ. 4.6 Vp-p)
- 2) Noise output : Max. 250 mVp-p (Typ. 90 mVp-p)
- 3) Balance output : Max. 15 %

$$\left[\frac{Bo}{|SA+SB|} \right] \leq 0.15$$

Bo : Balance output
SA : Signal output on Element A
SB : Signal output on Element B

MODEL NO. : SFG223-711	DRAWING NO.	REV : A	PAGE 2 / 9	
PART NO. :				

- 4) Operating voltage : 1 ~ 15 V dc (Rs: 47kohm)
- 5) Source voltage : 0.3 ~ 1.4 V (Vd: 5V, Rs: 47kohm)

※Test set-up block diagram See Fig.2.

※Test circuit configuration See Fig.3.

※Temperature conditions of 1,2,3,4 and 5 is 25 ± 5 degC.

Optical characteristics

- 1) Typical Field of view : 145 ° from center of element on axis X
 : 136 ° from center of element on axis Y
 : See Fig.1
- 2) Filter substrate : Silicon
- 3) Cut on (5 %T ABS) : 5.0 (+/-) 1.0 micron
- 4) Transmission : ≥ 70 % average 8 to 13 micron

Environmental requirements

- 1) Operating temperature : -40 degC to +70 degC
- 2) Storage temperature : -40 degC to +80 degC
- 3) Operating humidity : 95%RH or less (at 30degC)
- 4) Storage humidity : 95%RH or less (at 30degC)

RoHS compliance

This product conforms to the RoHS Directive in force at the date of issuance of this Specification Sheet.

MODEL NO. : SFG223-711	DRAWING NO.	REV : A	PAGE 3 / 9	 NIPPON CERAMIC CO., LTD.
PART NO. :				

Inspection

- 1) Process inspection :
100% inspection: Signal output, Balance output, Noise output and Source voltage

- 2) Outgoing inspection :
Electrical characteristics (except 4) and appearance are to be inspected for every production batch with complying with ANSI/ASQC Z1.4.

Packing

Packing specification is shown on Page 7.

Action at the time of defective occurrence

When defective occurs in incoming inspection and/or process inspection after the delivery, please return products with accompanying defective description note. We will analyze the defective cause regardless of your extra process on the defective products and decide the accounting action after discussion of both parties according to the defective cause.

Matter for consultation

Revision of this specification should be proceeded in writing after discussion of both parties.

MODEL NO. : SFG223-711	DRAWING NO.	REV : A	PAGE 4 / 9	 NIPPON CERAMIC CO., LTD.
PART NO. :				

Configuration (Fig.1)

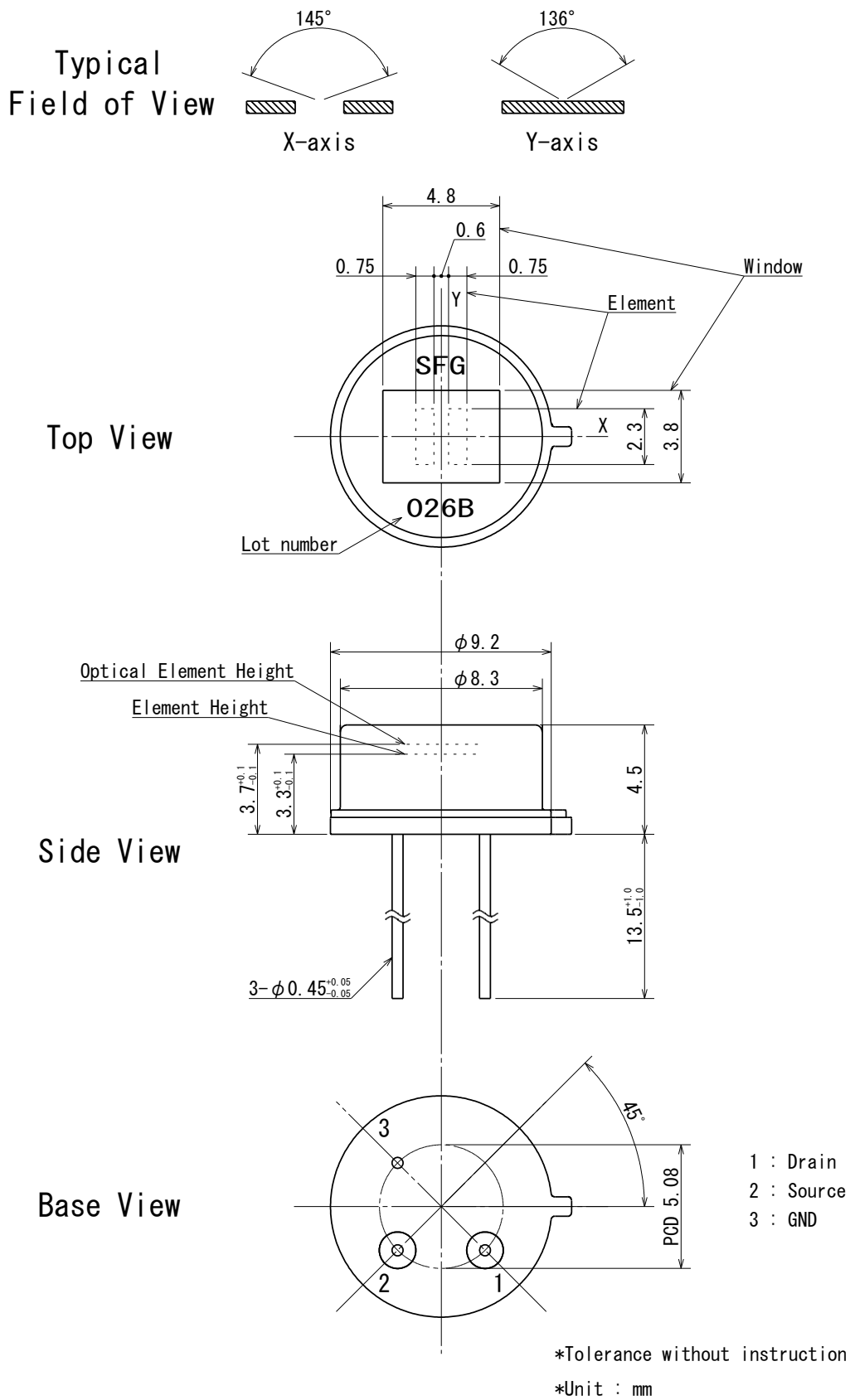

MODEL NO. : SFG223-711	DRAWING NO.	REV : A	PAGE 5 / 9	NIPPON CERAMIC CO., LTD.
PART NO. :				

Test set-up block diagram (Fig.2)

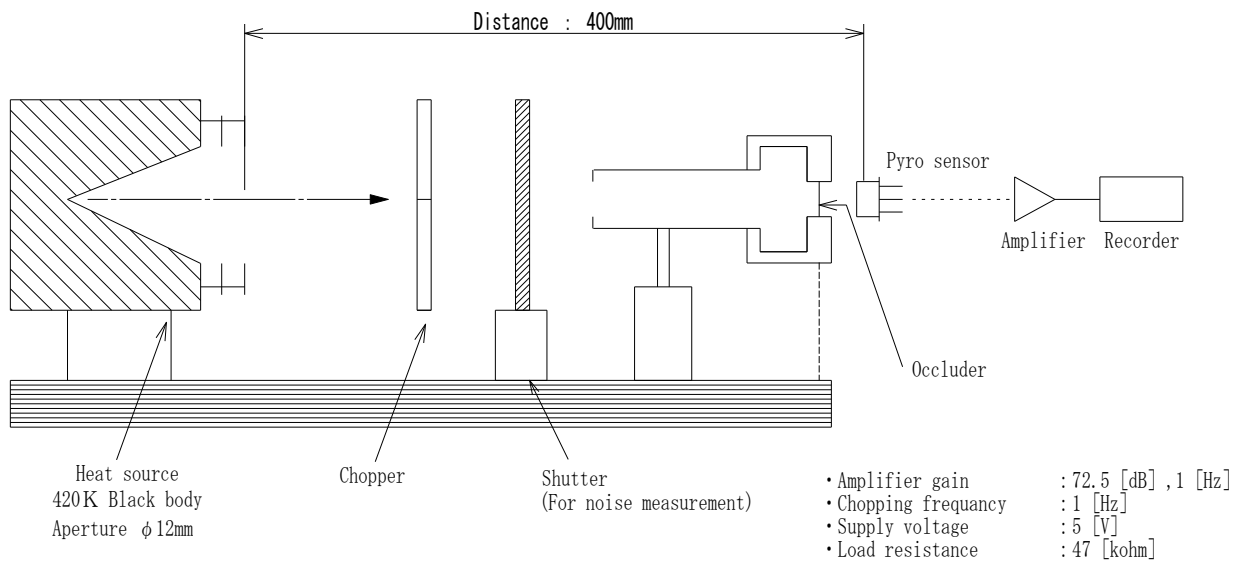

Occluder position

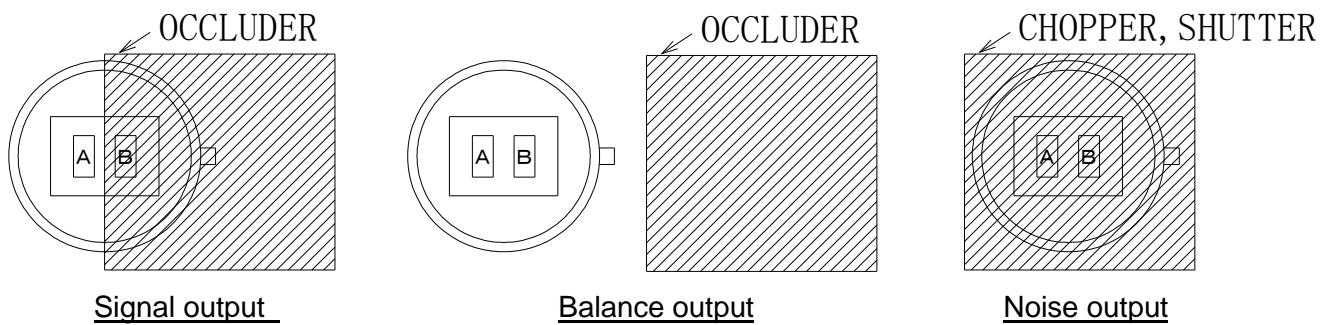

Test circuit configuration (Fig.3)

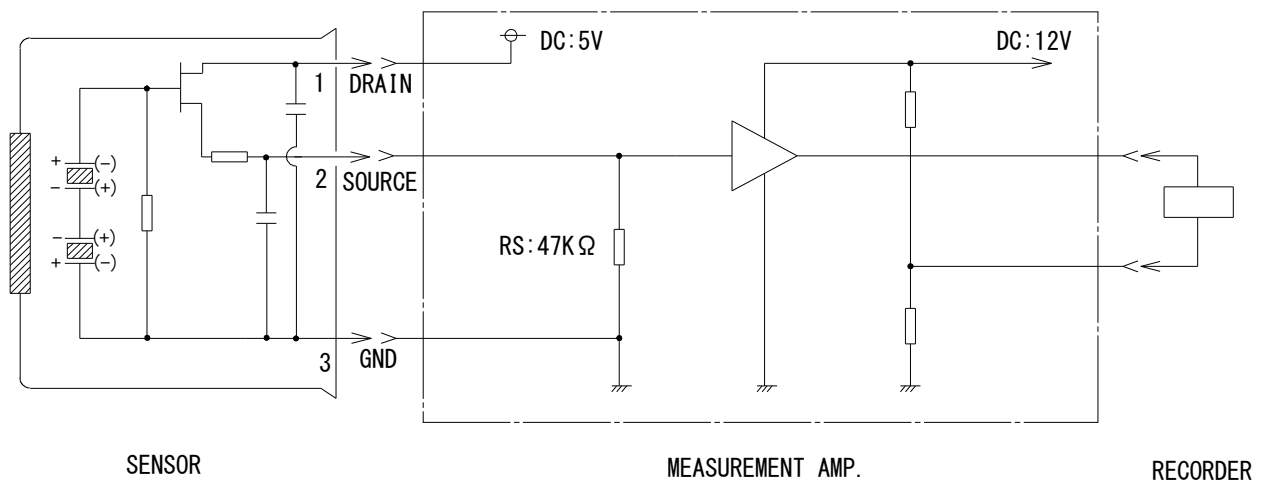

MODEL NO. : SFG223-711	DRAWING NO.	REV : A	PAGE 6 / 9	
PART NO. :				

Packing Specification

The products are packaged in inner box, and the boxes are piled up as shown on the following sketch.

1. Standard Package Quantity : 6,000 pcs.

2. Product arrangement 200 pcs./Sheet
400 pcs./Box

3. Packing

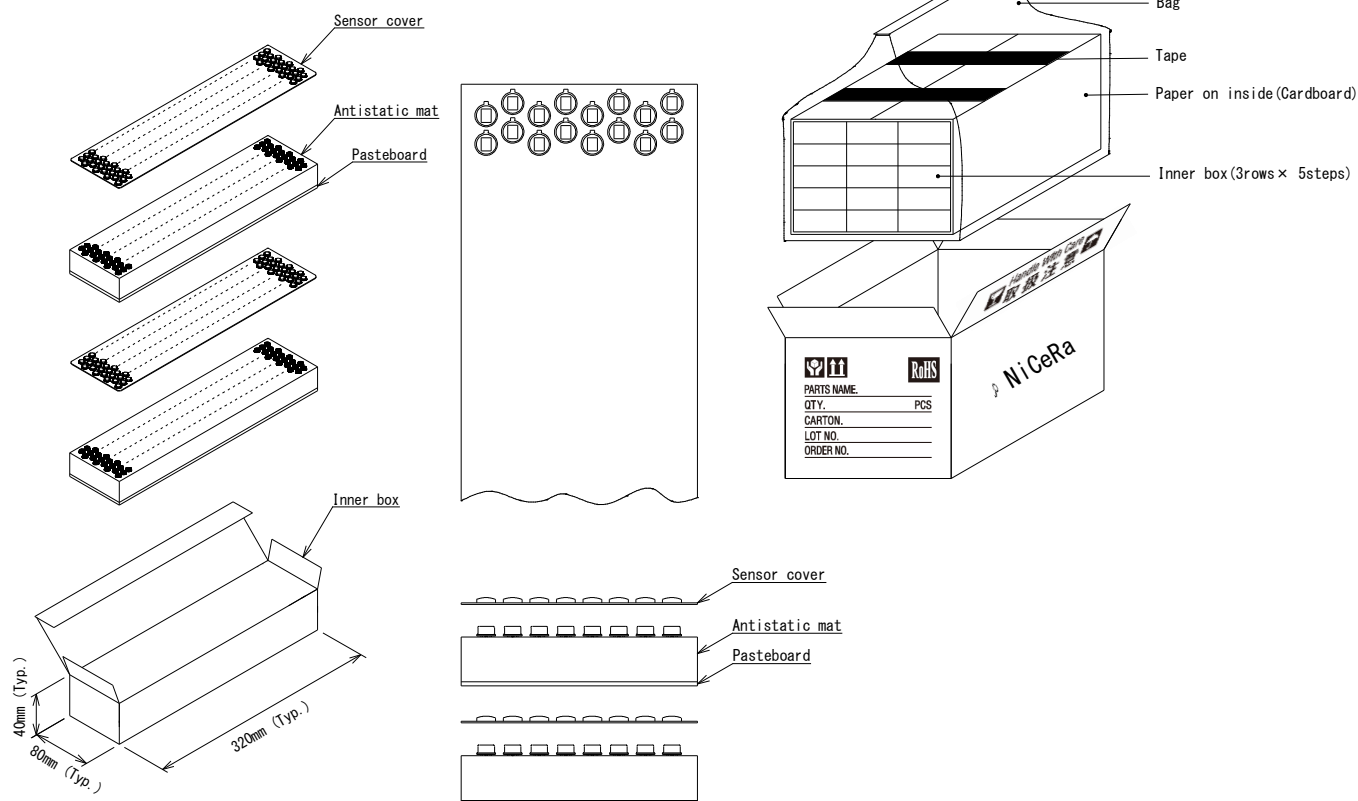

4. Packing in a box

The outer box is sealed with stick tape.

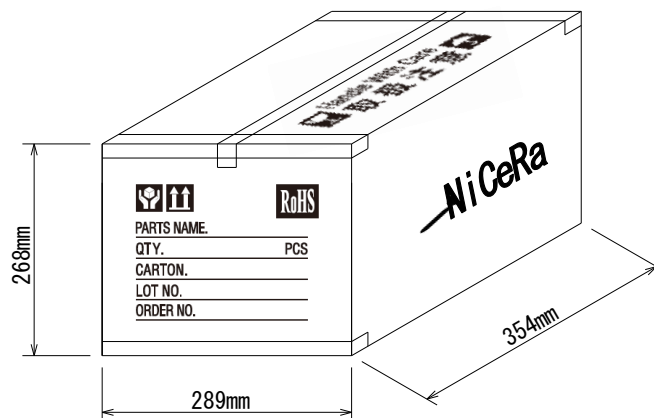

MODEL NO. : SFG223-711	DRAWING NO.	REV : A	PAGE 7 / 9	NIPPON CERAMIC CO., LTD.
PART NO. :				

※ Notes

1.Design restrictions/precautions

If used for outdoor applications, be sure to apply suitable supplementary optical filter and drip-proof, anti-dew construction. This sensor is designed for indoor use.

in cases where secondary accidents due to operation failure or malfunctions can be anticipated, add a fail safe function to the design.

2.Usage restrictions/precautions

To prevent sensor malfunctions, operational failure or any deterioration of its characteristics, do not use this sensor in the following, or similar, conditions.

- a. In rapid environmental temperature changes.
- b. In strong shock or vibration.
- c. In a place where there are obstructing materials (glass,fog,etc.) Through which Infrared rays cannot pass within detection area.
- d. In fluid, corrosive gases and sea breeze.
- e. Continual use in high humidity atmosphere.
- f. Exposed to direct sun light or headlights of automobiles.
- g. Exposed to direct wind from a heater or air conditioner.

3.Assembly restrictions/precautions

Soldering _____

- a. Use soldering irons when soldering.
- b. Avoid keeping pins of this sensor hot for a long time as excessive heat may cause deterioration of its quality.(e.g. within 5 sec. at 350 degC)

MODEL NO. : SFG223-711	DRAWING NO.	REV : A	PAGE 8 / 9	 NIPPON CERAMIC CO., LTD.
PART NO. :				

4. Handling and storage restrictions / precautions

To prevent sensor malfunctions, operational failure, appearance damage or any deterioration of its characteristics, do not expose this sensor to the following or similar, handling and storage conditions.

- a. Vibration for a long time.
- b. Strong shock.
- c. Static electricity or strong electromagnetic waves.
- d. High temperature and humidity for a long time.
- e. Corrosive gases or sea breeze.
- f. Dirty and dusty environments that may contaminate the optical window.
- g. Cleaning using an ultrasonic washing machine.

5. Remarks

- a. This product is not suitable for applications that require extremely high reliability, such as related to human life (life supporting devices and etc.).
- b. This specification guarantees the quality of sensor itself. In the occasion of use, please be sure to evaluate and verify performance in the state of assembly in your products.
- c. Please be reminded that we are not responsible for the malfunction caused by using this product deviating from the contents of this specification.
- d. This product should not be used for products prohibited to manufacture, use and sell by domestic and foreign laws and orders.

MODEL NO. : SFG223-711	DRAWING NO.	REV : A	PAGE 9 / 9	 NIPPON CERAMIC CO., LTD.
PART NO. :				