

Single-Phase DC Fan Driver

Features

- Speed Controllable by CMD (DC / PWM) Input
- Adjustable Speed curve (XP1 / YP1 / YMD / YP2)
- PWM Soft Switching
- Adjustable Leading Angle and Auto-off Function
- Adjustable current limit level
- Adjustable Soft-start time
- SO Speed Output (4pole / 6pole / 8pole / 2FG / RD)
- Lock Protection and Automatic Restart
- Over Current Protection
- TSSOP-16 Package

General Description

M8130 is designed for single phase motor driver that is composed of H-bridge power MOS. It's suitable for cooler DC fan that needs silent drivers, and it has auto dead-zone function that can reduce power dissipation.

Applications

- Cooling fan

Ordering Information

ORDER NUMBER	MARKING	TEMP. RANGE	PACKAGE (Green)
M8130FC1U	8130	-40°C to +105°C	TSSOP-16 (FD)

Note: FC: TSSOP-16 (FD)

1: Bonding Code

U: Tape & Reel

Green : Lead Free / Halogen Free

Pin Configuration

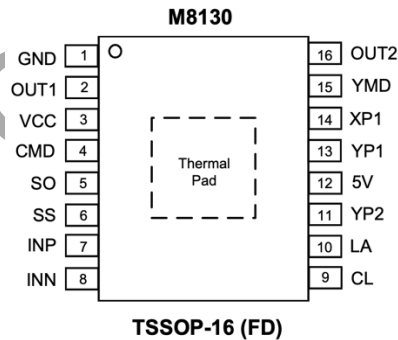

Note: Recommend connecting the Thermal Pad to the Ground for excellent power dissipation.

Absolute Maximum Ratings

VCC to GND -0.3V to 31V
VCC to GND Peak Voltage under 100nS 35V
5VREG to GND -0.3V to 7V
5VREG Output Source Current 30mA
OUT1, OUT2 Output Peak current 1.5A
OUT1, OUT2 Output Voltage -0.3V to VCC
SO Output Voltage -0.3V to VCC
SO Output Current 10mA
CMD to GND -0.3V to VCC
XP1, YP1, YMD, YP2, LA, CL, SS Pin to GND
. -0.3V to 7V
Thermal Resistance Junction to Case, (θ_{JC})
TSSOP-16 (FD) 25°C/W

Continuous Power Dissipation ($T_A=25^\circ\text{C}$)
TSSOP-16 (FD) 1.5W
Operating Temperature Range -40°C to $+105^\circ\text{C}$
Junction Temperature $+150^\circ\text{C}$
Storage Temperature Range -65°C to $+150^\circ\text{C}$
Reflow Temperature (soldering, 10sec) 260°C
ESD (HBM)4KV
ESD (MM)400V

TSSOP-16 Pin Thermal Derating Curve

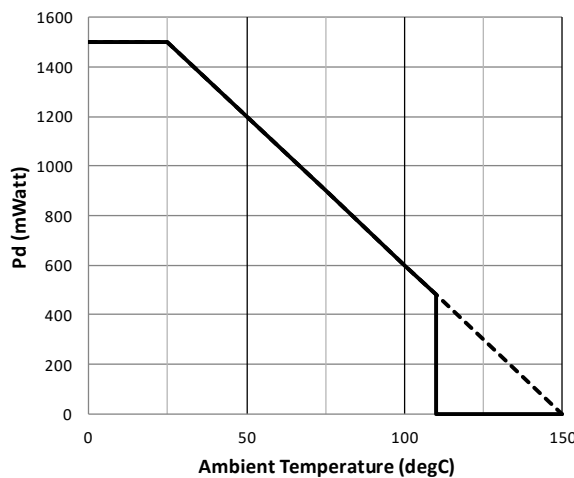

Note : When glass epoxy board (double layer) of 35mmx35mmX1.2mm is mounted.

Recommended Operating Conditions

PARAMETER	SYMBOL	MIN	TYP	MAX	UNIT
Power Supply Voltage	V_{CC}	6.2	24	29	V
Common-Mode Hall Input Voltage Range	V_{ICM}	0.4	---	$V_{5VREG}-0.4$	V
XP1 PIN Input Voltage	V_{XP1}	0	---	V_{5VREG}	V
YP1 PIN Input Voltage	V_{YP1}	0	---	V_{5VREG}	V
YMD PIN Input Voltage	V_{YMD}	0	---	V_{5VREG}	V
YP2 PIN Input Voltage	V_{YP2}	0	---	V_{5VREG}	V
LA PIN Input Voltage	V_{LA}	0	---	V_{5VREG}	V
CL PIN Input Voltage	V_{CL}	0	---	V_{5VREG}	V
SS PIN Input Voltage	V_{SS}	0	---	V_{5VREG}	V

Electrical Characteristics

$V_{CC}=24V$; $T_A = T_J = 25^{\circ}C$.

The device is not guaranteed to function outside its operating conditions. Parameters with MIN and/or MAX limits are 100% tested at $+25^{\circ}C$, unless otherwise specified.

PARAMETER	SYMBOL	CONDITION	MIN	TYP	MAX	UNIT
Power Supply						
Operating Current	I_{VCC}		2	3	4	mA
Shutdown Current	I_Q	PWM = GND	300	400	500	μA
Power on Delay						
Power ON delay Time	T_{td}	$V_{CC} = 0V$ to $12V$ $XP1 > 2.5V$	14	20	26	ms
Power ON delay Time	T_{td}	$V_{CC} = 0V$ to $12V$ $XP1 < 2.5V$	70	100	130	ms
PWM Mode						
CMD Input Low Voltage	V_{CMDL}		0	---	0.8	V
CMD Input High Voltage	V_{CMDH}		2	---	V_{CC}	V
CMD Pull High Current	I_{CMD}	$YP1 < 0.15V$ & $LA > 4.75V$	15	20	30	μA
CMD Pull High Current	I_{CMD}		150	200	250	μA
PWM Input Frequency	F_{PWM}		0.1	---	50	kHz
Output Switch Frequency	F_{OUT}	V_{MODE_SEL} floating	55	64	75	kHz
Internal Regulator						
5V Regulator Output Voltage	V_{SVREG}	$I_{SVREG} = -10mA$	4.9	5	5.1	V
5V Regulator Current Limit	I_{SVOC}		20	25	30	mA
Output Drivers						
High-side Output Voltage	V_{OH}	$V_{CC} = 24V$, $I_{OUT} = 200mA$		0.65	0.845	Ω
Low-side Output Voltage	V_{OL}	$V_{CC} = 24V$, $I_{OUT} = 200mA$		0.3	0.39	Ω
SO Low Voltage	V_{SOL}	$I_{SO} = 5mA$	---	0.2	0.3	V
SO Off Leakage Current	I_{SOL}	$V_{SO} = 24V$	---	2	4	μA
Current Protection						
Current Limit level	I_{LIM}	Normal	0.9	1	1.1	A
Over current protection level	I_{OC}		---	1.5	---	A
Lock Protection						
Re-start Time	T_{on}		0.5	0.75	1	Sec
Lock Mode Time	T_{off}		3.5	5	6.5	Sec
Thermal Protection						
Thermal Protection Temp.	T_{TSD}		---	165	---	$^{\circ}C$
Thermal Protection Hysteresis	T_{HYS}		---	30	---	$^{\circ}C$

Pin Description

PIN NO.	SYMBOL	DESCRIPTION
TSSOP-16		
1	GND	Ground
2	OUT1	Motor output terminal 1
3	VCC	Power Supply
4	CMD	Speed Control
5	SO	Rotation Speed/Detection Output
6	SS	Duty soft start
7	INP	Hall + input terminal
8	INN	Hall - input terminal
9	CL	Current Limit level
10	LA	Leading Angle Setting
11	YP2	Maximum Output PWM Duty Setting
12	5VREG	5V Regulator Output
13	YP1	Minimum Output PWM Duty Setting
14	XP1	Minimum Input PWM Duty Setting
15	YMD	Mid Output PWM Duty Setting at PWM duty=75%
16	OUT2	Motor output terminal 2

For Foxconn Only

Block Diagram

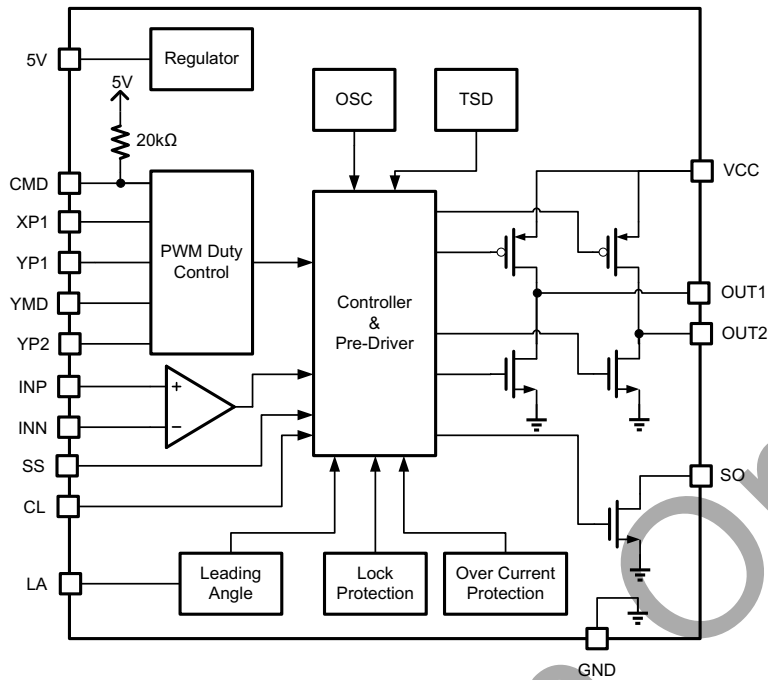

Application Circuit Examples

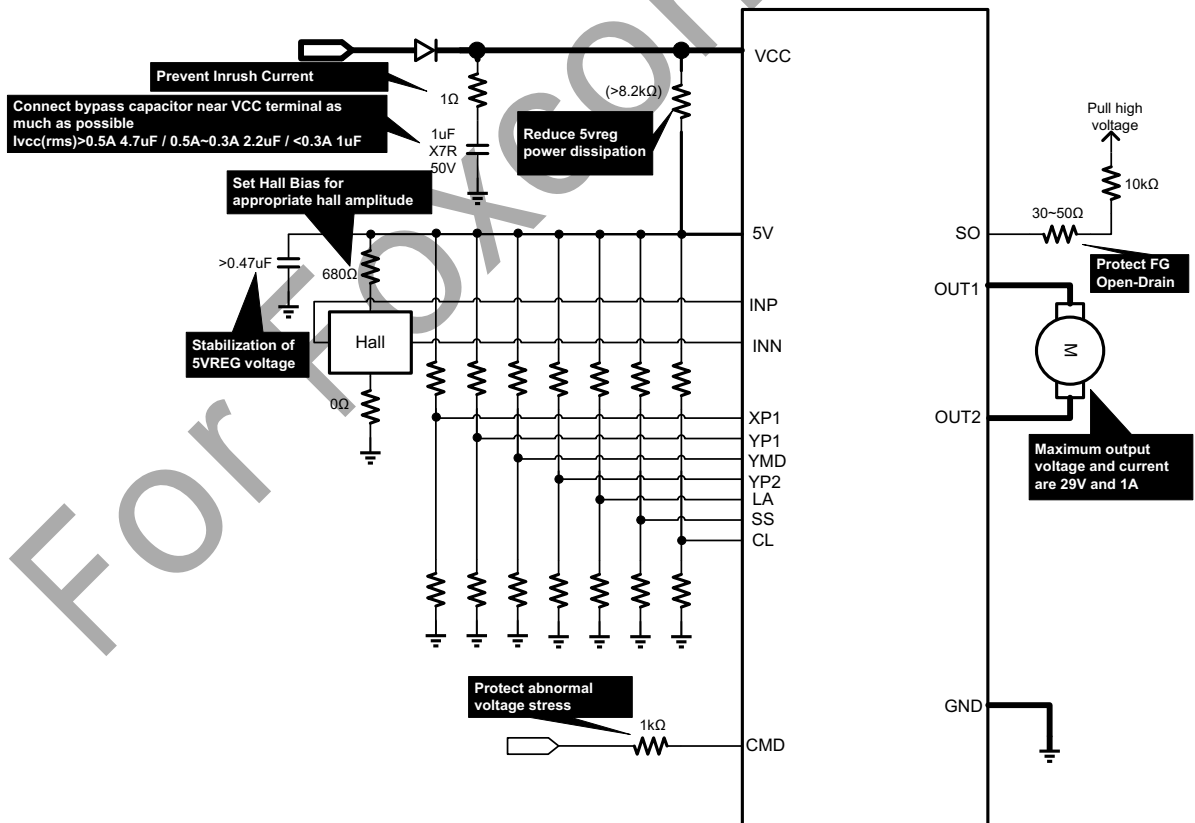

Function Descriptions

Speed Control Setting

The XP1 / YP1 / YMD / YP2 is detected by ADC which has 256 steps, and the resolution is 15.625mV/step. As a result, the ADC can detect voltage from 0.5V(ADC=0) to 4.5V(ADC=255).

(A) The XP1 pin is a multi function pin setting by voltage from 0V ~ 5V. The main function controls the turning point of input low duty at speed curve. The second function is to set speed curve with shutdown or minimum speed.

Equation :

$$D_{XP1} = \left(\frac{V_{IN}}{15.625mV} \times \frac{5}{8} + 12 \right) \times \frac{50\%}{128}$$

$$V_{XP1} > 2.5V, V_{IN} = 4.5V - V_{XP1}$$

$$V_{XP1} < 2.5V, V_{IN} = V_{XP1} - 0.5V$$

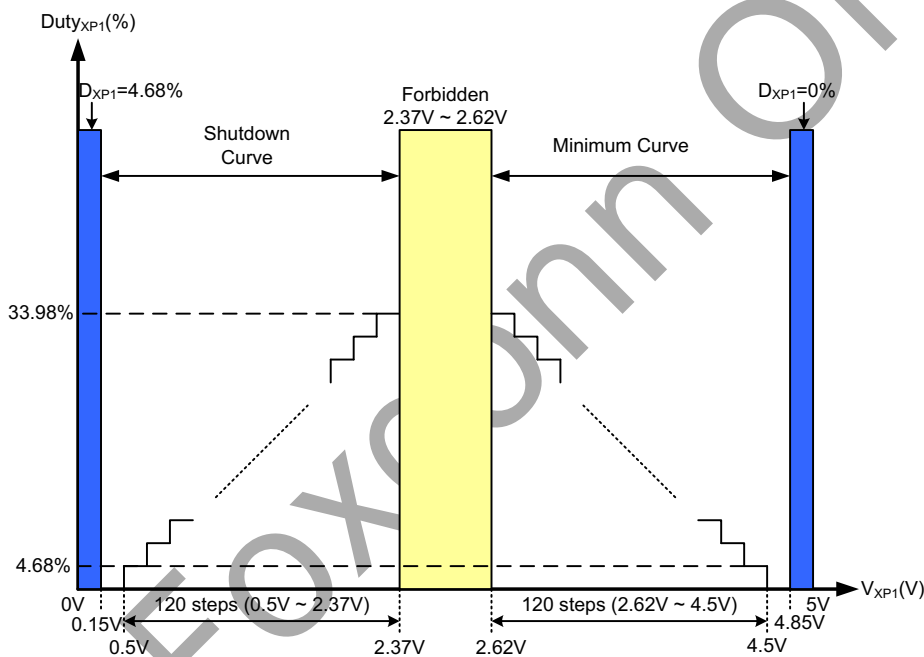

Figure : XP1 Voltage Setting Range

Table : XP1 Voltage Setting Table

Step	VXP1 (V)	Duty output (%)	Sec. Function
	>4.85	0	Minimum
255	4.5	4.68	
136	2.62	33.98	
Forbidden			
120	2.37	33.98	Shutdown
0	0.5	4.68	
	<0.15	4.68	

(B) The YP1 pin is a multi function pin setting by voltage from 0V ~ 5V. The main function controls the turning point of output low duty at speed curve. The second function is to set SO PIN with FG or RD.

Equation :

$$D_{YP1} = \left(\frac{V_{IN}}{15.625mV} \times \frac{5}{8} + 12 \right) \times \frac{50\%}{128}$$

$$V_{YP1} > 2.5V, V_{IN} = 4.5V - V_{YP1}$$

$$V_{YP1} < 2.5V, V_{IN} = V_{YP1} - 0.5V$$

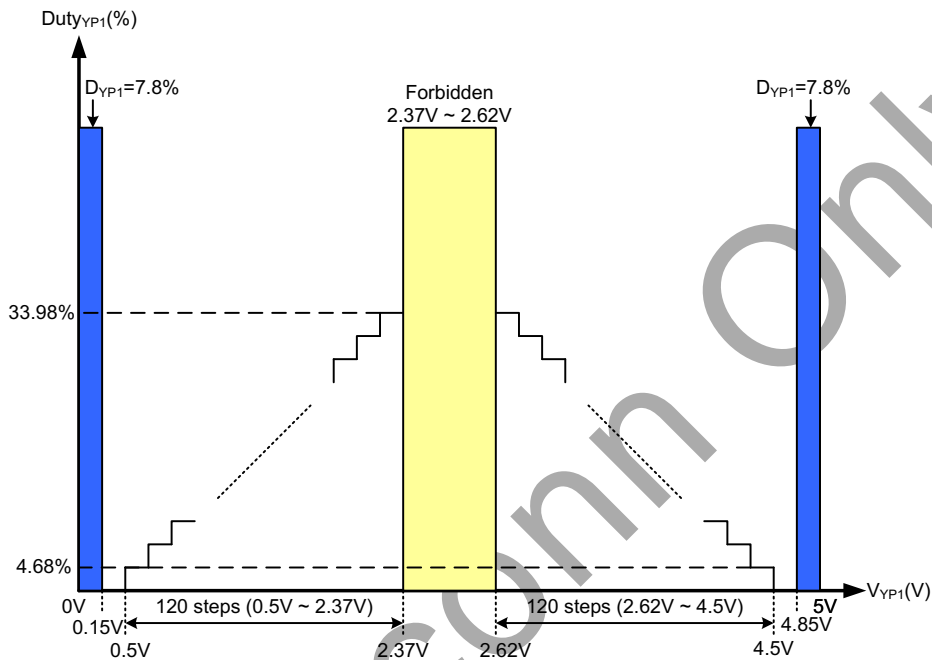

Figure : YP1 Voltage Setting Range

Table : YP1 Voltage Setting Table

Step	V _{YP1} (V)	Duty output (%)	Sec. Function
	>4.85	7.8	SO Select
255	4.5	4.68	
136	2.62	33.98	
Forbidden			
120	2.37	33.98	SO Select
0	0.5	4.68	
	<0.15	7.8	

(C) The YMD pin is a multi function pin setting by voltage from 0V ~ 5V. The main function controls

Equation :

$$D_{YMD} = \left(\frac{V_{IN}}{15.625mV} \times \frac{13}{16} \right) \times \frac{50\%}{128} + 128$$

$$V_{YMD} > 2.5V, V_{IN} = V_{YMD} - 2.5V$$

$$V_{YMD} < 2.5V, V_{IN} = 2.5V - V_{YMD}$$

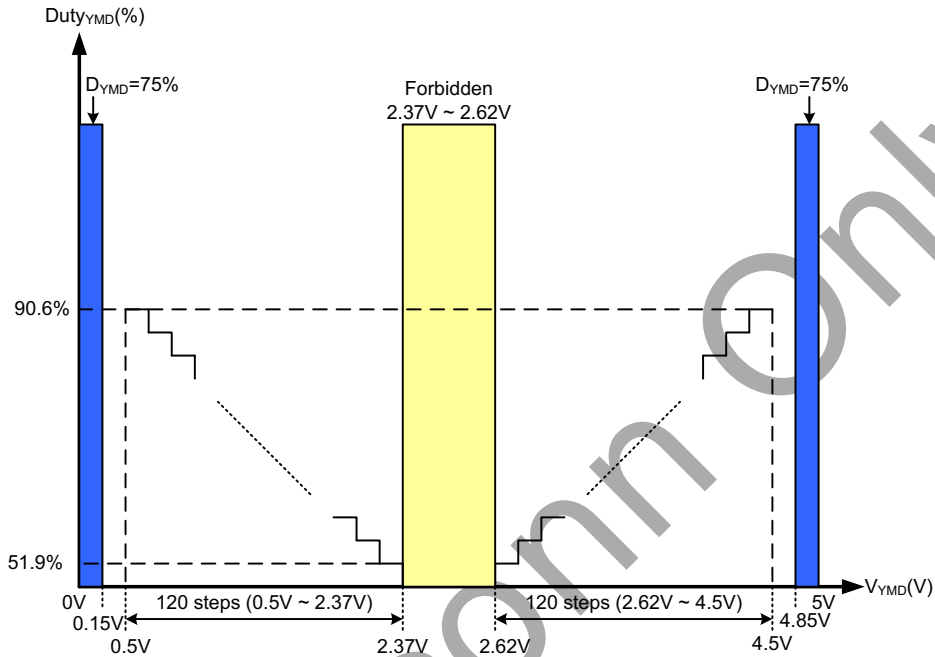

Figure : YMD Voltage Setting Range

Table : YMD Voltage Setting Table

Step	V _{YMD} (V)	Duty output (%)	Sec. Function
	>4.85	Disable	SO Select
255	4.5	90.6	
136	2.62	52.5	
Forbidden			
120	2.37	52.5	SO Select
0	0.5	90.6	
	<0.15	Disable	

(C) The YP2 pin is a multi function pin setting by voltage from 0V ~ 5V. The main function controls the turning point of output high duty at speed curve. The second function is to set SO PIN with FG or 2FG. The third function is to set CMD PIN with VSP mode ($V_{YP2} = 4.28V \sim 4.5V$) or SET mode ($V_{YP2} = 0.5V \sim 0.71V$).

Equation :

$$D_{YP2} = \frac{V_{IN}}{15.625mV} \times \frac{50\%}{128} + 50\%$$

$$V_{YP2} > 2.5V, V_{IN} = V_{YP2} - 2.5V$$

$$V_{YP2} < 2.5V, V_{IN} = 2.5V - V_{YP2}$$

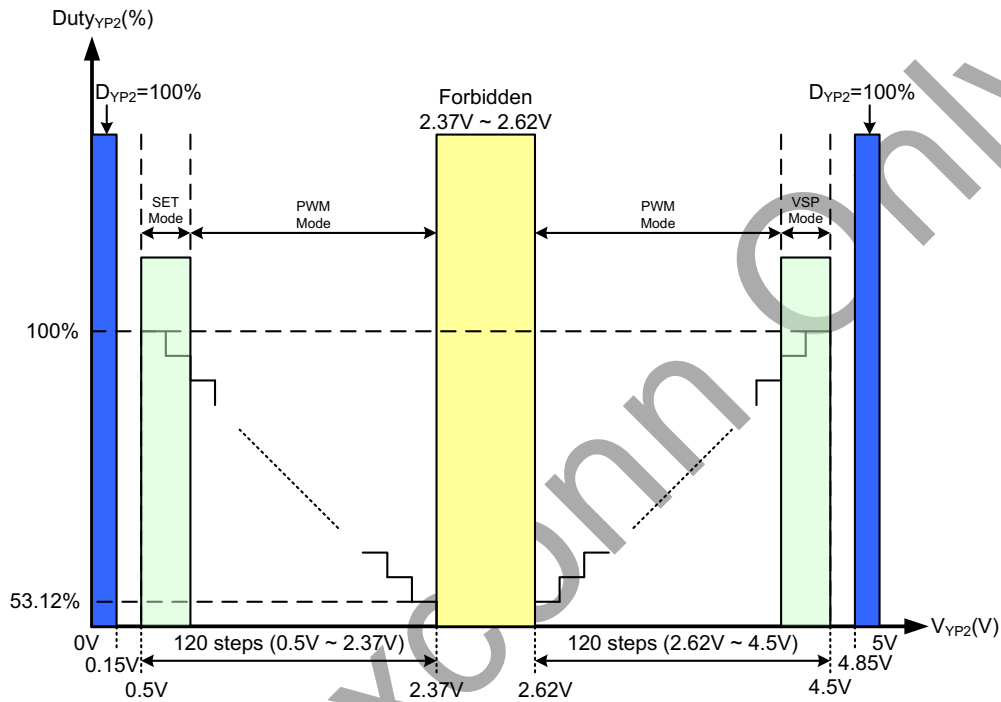

Figure : YP2 Voltage Setting Range

Table : YP2 Voltage Setting Table

Step	VYP2 (V)	Duty Output (%)	Thir. Function	Thir. Function	
	>4.85	100	---	Soft Switch Type	
255	4.5	100	VSP Mode		
246	4.34	96	---		
136	2.62	53.12	---	Soft Switch Type	
Forbidden					
120	2.37	53.12	---		
10	0.65	96	---	Soft Switch Type	
0	0.5	100	Set Mode		
	<0.15	100	---		

Phase Control Setting

The LA pin is a multi function pin setting by voltage from 0V ~ 5V. The main function controls the leading angle based on real hall signal. The second function is to set output signal shape with sine wave or soft switch.

Equation :

$$P_{LA} = \left(\frac{V_{IN}}{15.625mV} \right) \times \frac{22.5^\circ}{128}$$

$$V_{LA} > 2.5V, V_{IN} = 4.5V - V_{LA}$$

$$V_{LA} < 2.5V, V_{IN} = V_{LA} - 0.5V$$

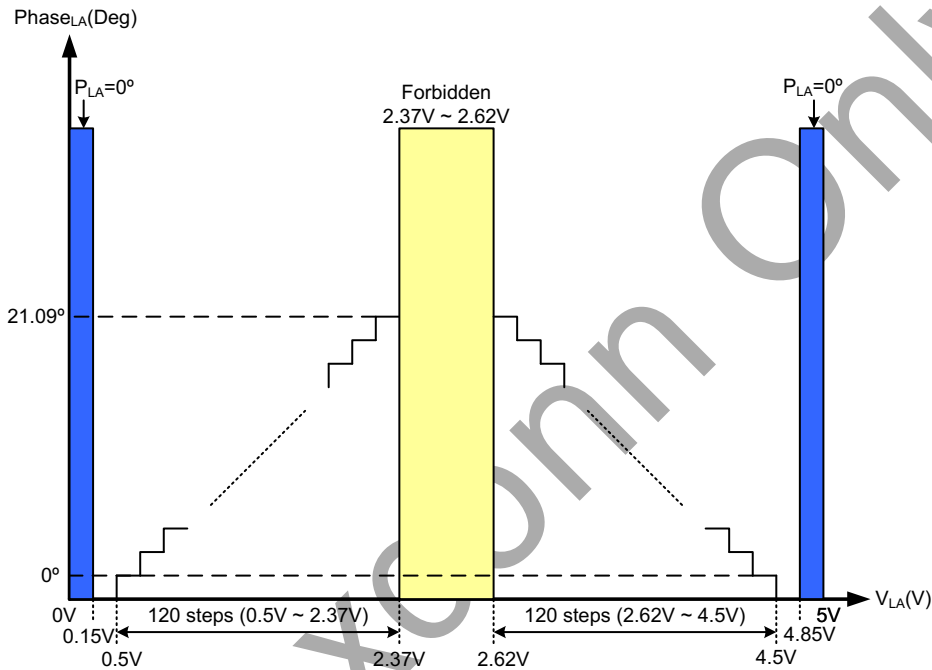

Figure : LA Voltage Setting Range

Table : LA Voltage Setting Table

Step	VLA (V)	LA (Deg)	Sec. Function
	>4.85	0	Soft Switch Type
255	4.5	0	
136	2.62	21.09	
Forbidden			
120	2.37	21.09	Soft Switch Type
0	0.5	0	

Truth Table
(A) Hall vs. Driver output

Hall Input			Output				Mode
INP	INN	VINN	OUT1	OUT2	FG	RD	
H	L	< 2.5V	L	H	Hi-Z	L	Normal (PWM=H)
L	H		H	L	L	L	
H	L		L	Hi-Z	Hi-Z	L	Normal (PWM=L)
L	H		Hi-Z	L	L	L	
H	L		L	Hi-Z	Hi-Z	Hi-Z	Lock
L	H		Hi-Z	L	Hi-Z	Hi-Z	
H	L	> 2.5V	H	L	L	L	Normal (PWM=H)
L	H		L	H	Hi-Z	L	
H	L		Hi-Z	L	L	L	Normal (PWM=L)
L	H		L	Hi-Z	Hi-Z	L	
H	L		Hi-Z	L	Hi-Z	Hi-Z	Lock
L	H		L	Hi-Z	Hi-Z	Hi-Z	

H : High, L : Low, Hi-Z : High Impedance

(B) Mode select

Mode	1			2
	SO = RD	SET / VSP	Normal	YP1 < 0.15V LA > 4.85V (only sinewave)
CMD Pull high	200μA	NA	200μA	20μA
5V OFF (shutdown mode)	NA	NA	Yes	NA
2FG	No	No	No	Yes

(C) Soft Switch Type

	22.5°C	square	45°C	sinewave
LA	0	0	1	1
YP2	0	1	0	1

※PIN voltage > 2.5V means 1, and PIN voltage < 2.5V means 0.

(D) SO Type

	FG	$\frac{4}{8}FG$	RD	$\frac{4}{6}FG$
YP1	1	1	0	0
YMD	1	0	1	0

※PIN voltage > 2.5V means 1, and PIN voltage < 2.5V means 0.

Current Limit

The M8130 includes internal current limit. It will turn off high side PMOS when output driver current is over 1A. The high side PMOS will turn on at next PWM cycle, and reduce the output duty. The M8130 also includes over current protection (OCP). If the output driver current is over 1.5A, all output MOS will turn off and enable lock protection. Chip will restart when lock off time is count down.

Lock Protection and Automatic Restart

Motor rotation is detected by hall signal. When the fan encounters an external force, result in hall signal fixed high and low. This chip internal clock detect an on time (T_{ON} 0.5s), then all driver MOSFETs are turned off and auto restart after the recovery time (T_{OFF} 5s).

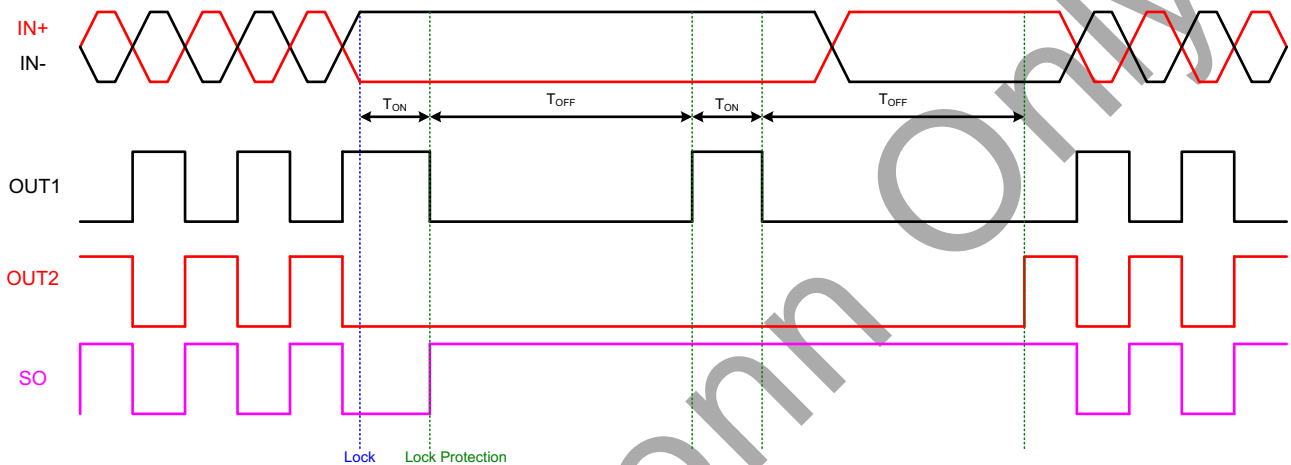

I/O Equivalence Circuit

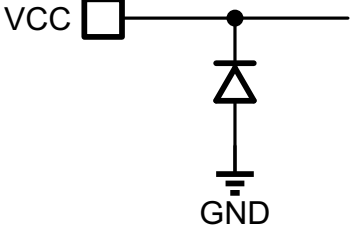
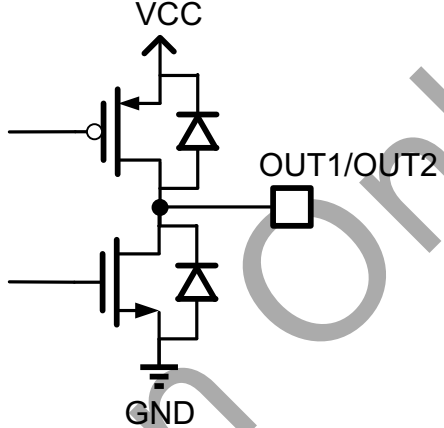
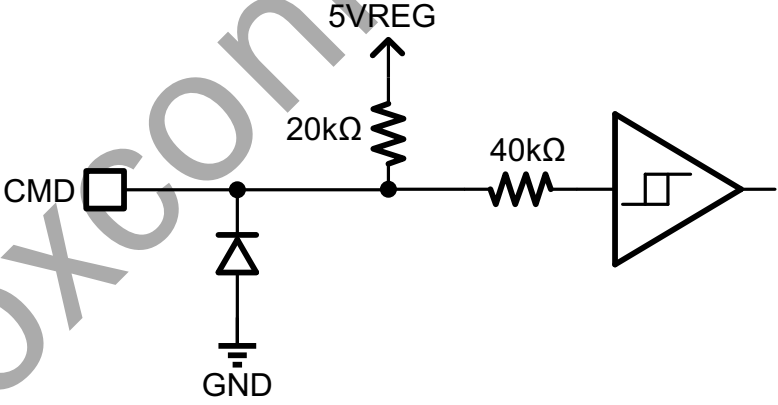
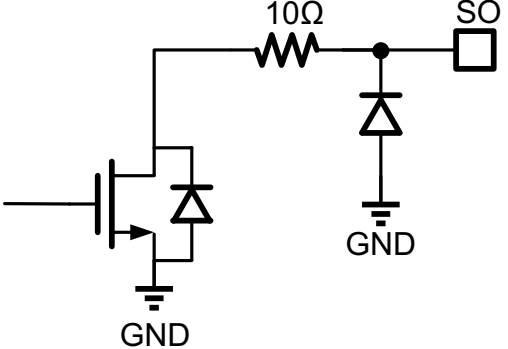
PIN	I/O	Equivalence Circuit
Power supply (VCC / GND)	Input	
OUT1 / OUT2	Output	
CMD	Input	
	Output	

I/O Equivalence Circuit

PIN	I/O	Equivalence Circuit
Reference voltage 5VREG	Output	
Hall Signal INP / INN	Input	
XP1 / YP1 / YMD / YP2 / LA / SS / CL	Input	

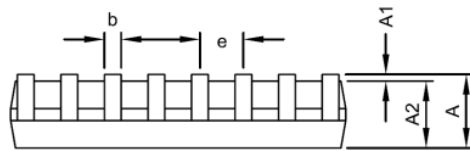
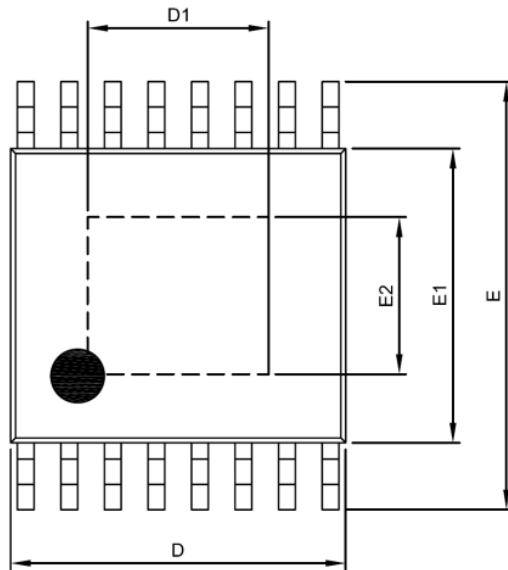
Package Information

TSSOP-16 (FD) Package

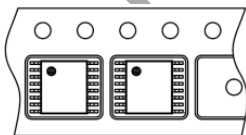
Symbol	DIMENSION IN MM			DIMENSION IN INCH		
	MIN.	NOM.	MAX.	MIN.	NOM.	MAX.
A	---	---	1.20	---	---	0.048
A1	0.00	---	0.15	0.000	---	0.006
A2	0.80	1.00	1.05	0.033	0.039	0.041
D	4.90	5.00	5.10	0.193	0.197	0.201
D1	2.40	2.70	3.00	0.094	0.106	0.118
E	6.20	6.40	6.60	0.244	0.252	0.260
E1	4.30	4.40	4.50	0.169	0.173	0.177
E2	1.70	2.35	3.00	0.067	0.093	0.118
c	0.09	---	0.20	0.004	---	0.008
b	0.19	0.22	0.30	0.008	0.009	0.012
e	0.65 BSC			0.026 BSC		
L	0.45	0.60	0.75	0.018	0.024	0.030

Taping Specification

Feed Direction

PACKAGE	Q'TY/BY REEL
TSSOP-16 (FD)	3,000 ea

GMT Inc. does not assume any responsibility for use of any circuitry described, no circuit patent licenses are implied and GMT Inc. reserves the right at any time without notice to change said circuitry and specifications.

For Foxconn Only