

3-Phase DC Fan Driver

Features

- Sinusoidal drive for low audible noise
- SVPWM output drive
- Sinusoidal start up low audible noise
- High efficiency control algorithm
- Sensorless operation
- PWM / VSP speed control
- SO speed output
(Support Pole 4P/8P/10P/12P/RD)
- Lock protection
- Over current protection
- Soft-start adjust
- WDFN3X3-10 package

General Description

M8321 is designed for 3 phase motor control, especially for cooling fan control, it includes 180° sinusoidal driving algorithm for low audible noise.

Applications

- Notebook
- Water Pump
- Refrigerator Fan
- Case / VGA / PC Fan

Ordering Information

ORDER NUMBER	MARKING	TEMP. RANGE	PACKAGE (Green)
M8321U31U	8321	-40°C to +105°C	WDFN3X3-10

Note: U3: WDFN3X3-10

1: Bonding Code

U: Tape & Reel

Green: Lead Free / Halogen Free

Pin Configuration

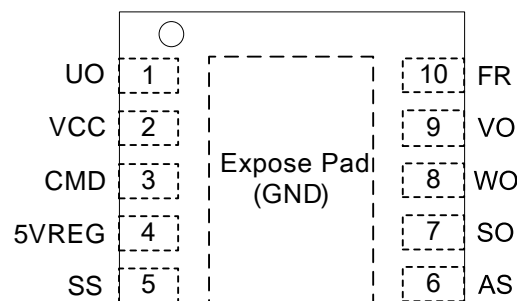

M8321U31U WDFN3X3-10

Absolute Maximum Ratings

VCC to GND Max Voltage. -0.3V to 18V
 VCC to GND Peak Voltage under 100nS 26V
 5VREG to GND -0.3V to 7V
 UO, VO, WO Output Peak current 2.25A
 UO, VO, WO Output Voltage -0.3V to VCC
 SO Output Voltage -0.3V to VCC
 SO Output Current 10mA
 CMD to GND -0.3V to VCC
 AS, SS Pin to GND -0.3V to 7V
 FR to GND -0.3V to VCC

Thermal Resistance of Junction to Ambient (θ_{JA})
 WDFN3X3-10 110 °C/W
 Continuous Power Dissipation ($T_A = +25^\circ\text{C}$)
 WDFN3X3-10. 1000 mW
 Operating Temperature Range -40°C to +105°C
 Junction Temperature +150°C
 Storage Temperature Range -65°C to +150°C
 Reflow Temperature (soldering, 10sec) 260°C
 ESD (HBM) 4KV
 ESD (MM) 400V

WDFN3X3-10Pin Thermal Derating Curve

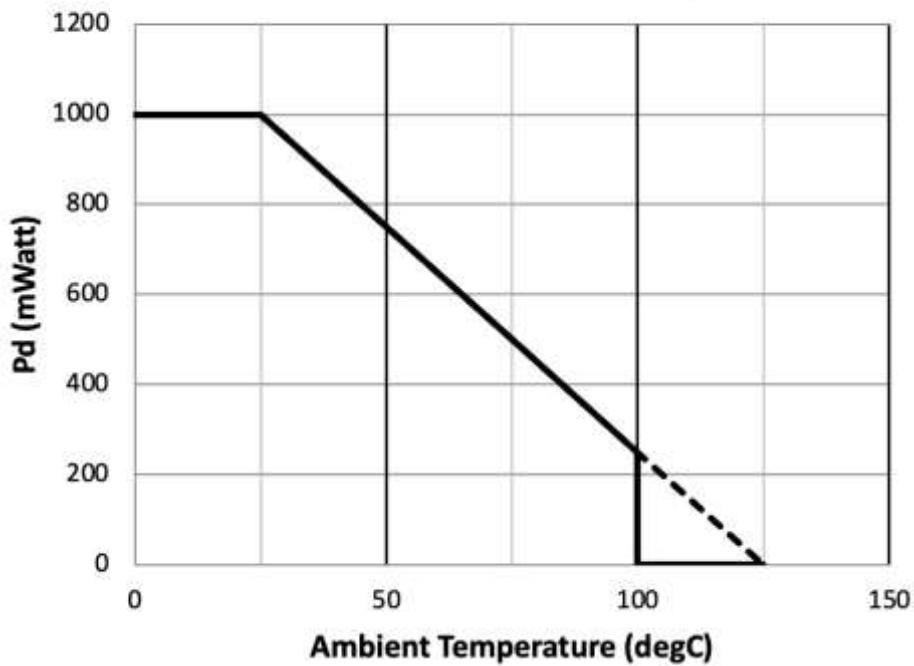

Electrical Characteristics

($V_{IN}=12V$; $T_A = T_J = 25^{\circ}C$.)

The device is not guaranteed to function outside its operating conditions. Parameters with MIN and/or MAX limits are 100% tested at +25°C, unless otherwise specified.

PARAMETER	SYMBOL	CONDITION	MIN	TYP	MAX	UNIT
V_{IN}						
Input Voltage	V_{CC}		3.5	12	18	V
Operating Current	I_Q		2.5	3	3.5	mA
Standby Current	I_{SB}	Mode1	200	---	500	μA
Power ON delay Time	T_{td}	$V_{CC} = 0V$ to 12V	96	120	144	mS
CMD Pin						
CMD Input Low Voltage	V_{CMDL}		0	---	0.8	V
CMD Input High Voltage	V_{CMDH}		2	---	V_{CC}	V
CMD Pull High Current	I_{CMD}	$V_{CMD} = 0V$ at Mode1	160	200	240	μA
CMD Pull High Current	I_{CMD}	$V_{CMD} = 0V$ at Mode2	16	20	24	μA
CMD Pull High Current	I_{CMD}	$V_{CMD} = 0V$ at Mode3	0	0	0	μA
PWM Input Frequency	F_{PWM}		0.1	---	50	KHz
Output Switch Frequency	F_{OUT}		50	62.5	75	KHz
VSP mode 3 Range	V_{CMD}	1.5V=10% output ; 3.5V=100% output	1.5		3.5	V
Internal Regulator						
5V Regulator Output Voltage	V_{5VREG}	$I_{5VREG} = -10mA$	4.9	5	5.1	V
5V Regulator Current Limit	I_{5VOC}		20	30	40	mA
Output Drivers						
High-side Output Voltage	V_{OH}	$V_{CC} = 12V$, $I_{OUT} = 750mA$		0.158	0.19	V
Low-side Output Voltage	V_{OL}	$V_{CC} = 12V$, $I_{OUT} = 750mA$		0.068	0.082	V
SO Low Voltage	V_{SOL}	$I_{SO} = 5mA$	0.2		0.3	V
SO Off Leakage Current	I_{SOL}	$V_{SO} = 12V$	---	---	1	μA
FR						
FR Input Low Voltage Threshold	V_{FR_VTHL}		1.06	1.11	1.16	V
FR Input High Voltage Threshold	V_{FR_VTHH}		1.15	1.2	1.25	V
FR Input Low Voltage Range	V_{FRL}	Reverse $V > U > W$	0	---	1.02	V
FR Input High Voltage Range	V_{FRH}	Forward $U > V > W$	1.29	---	V_{CC}	V
FR Pull Low Resistor	R_{FR}		100	120	140	$k\Omega$
RPM						
Max RPM	R_limit	2 pair pole (4P)	40000	50000	---	rpm
Current Protection						
Current Limit level	I_{LIM}	Start-up	0.348	0.435	0.522	A
Current Limit level	I_{LIM}	Normal	1.2	1.5	1.8	A
Over current protection level	I_{OC}		1.8	2.25	2.7	A
Lock Protection*1						
Lock Mode On Time	T_{on}	AS pin 1536rpm~192rpm	0.84	---	9.6	Sec
Lock Mode OFF Time	T_{off}		4	5	6	Sec
Lock Mode OFF Time 1st	T_{off_1st}		0.8	1	1.2	Sec
Thermal Protection						
Thermal Protection Temp.	T_{TSD}		155		175	$^{\circ}C$
Thermal Protection Hysteresis	T_{HYS}		---	30	---	$^{\circ}C$
Vzc Comparator						
Vzc Hysteresis Voltage 0.5Vcc to Floating Output	V_{zc}	Normal working Output (rise + fall) / 2	20	-	70	mV

Note

*1 : Lock Mode ON Time = Sinewave start-up time, defined by AS pin.

Pin Description

PIN	NAME	DESCRIPTION
1	UO	Motor Terminal U
2	VCC	Input Supply
3	CMD	Speed Control
4	5VREG	5V Regulator Output
5	SS	Output Duty Change Time Setting
6	AS	Start-Up Setting
7	SO	Rotation Speed Output
8	WO	Motor Terminal W
9	VO	Motor Terminal V
10	FR	Rotation Direction Control, High = U>V>W , Floating pull Low = V>U>W
Exposed Pad	GND	Ground

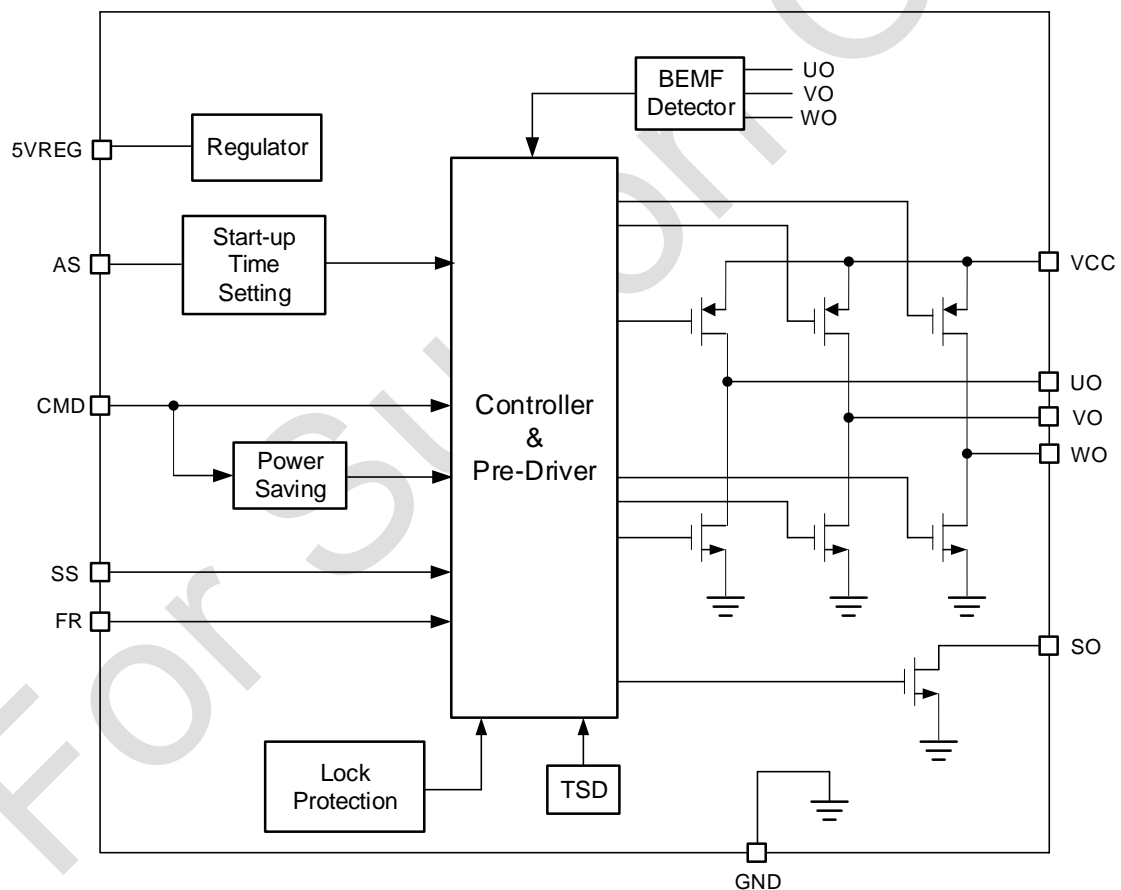
Block Diagram

Application Circuit Examples

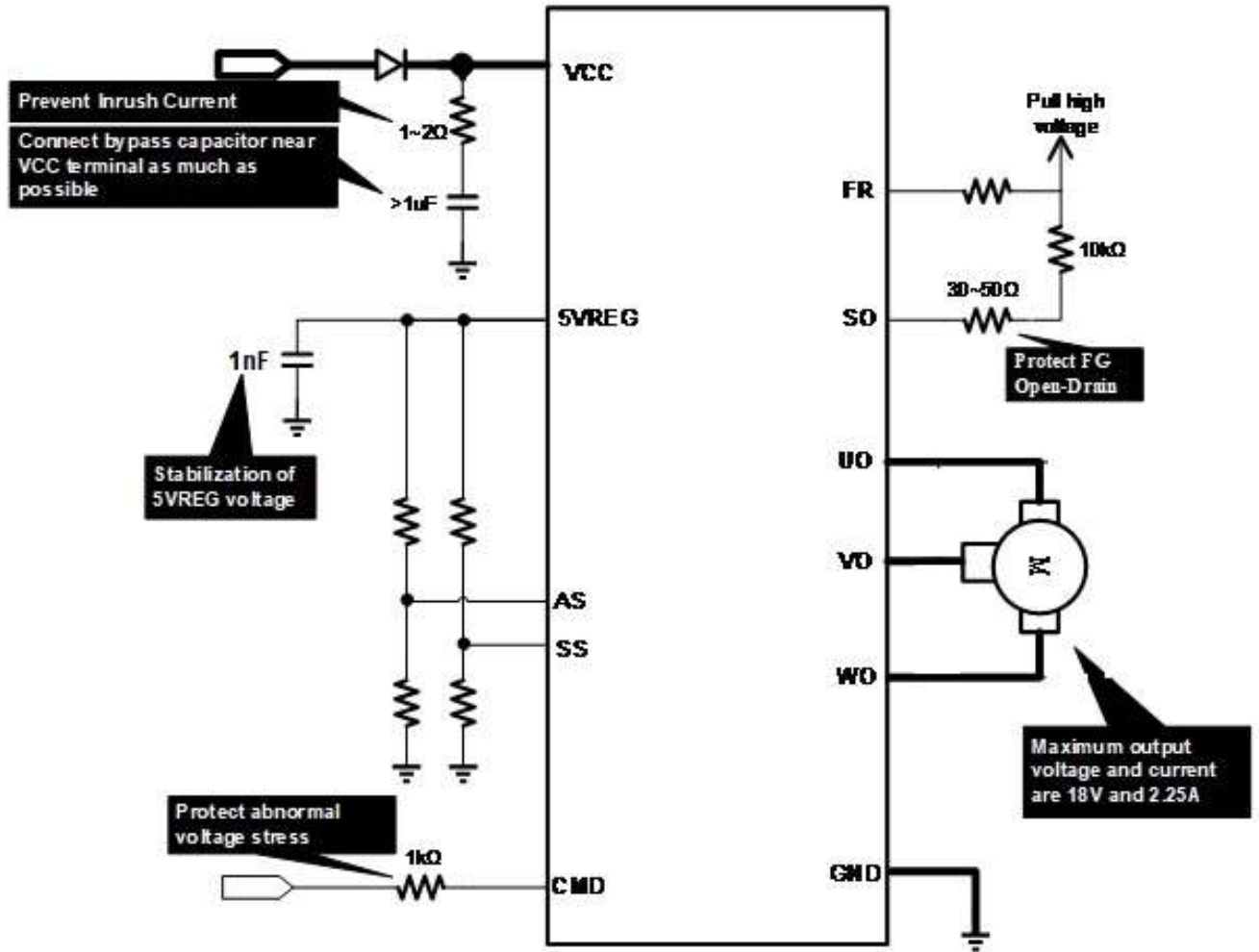

Start Up Waveform

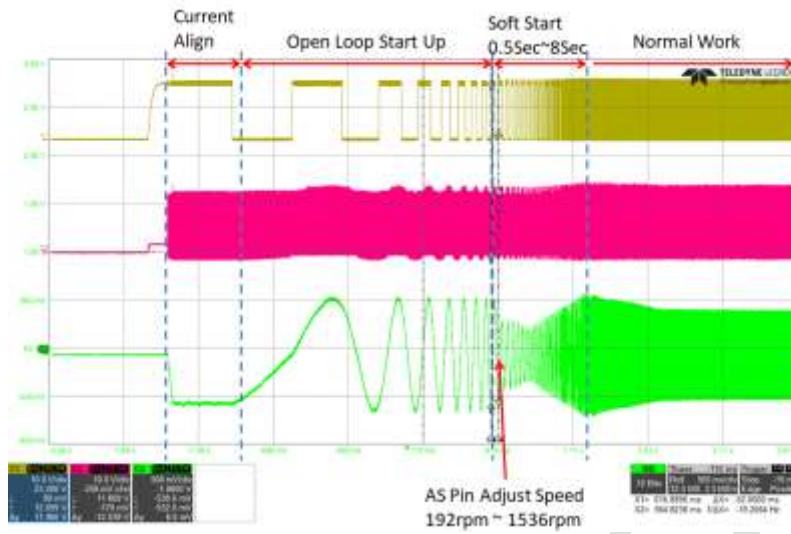

Ch1 : FG , Ch2 : Wo , Ch3 : Iw

Output Waveform SVPWM

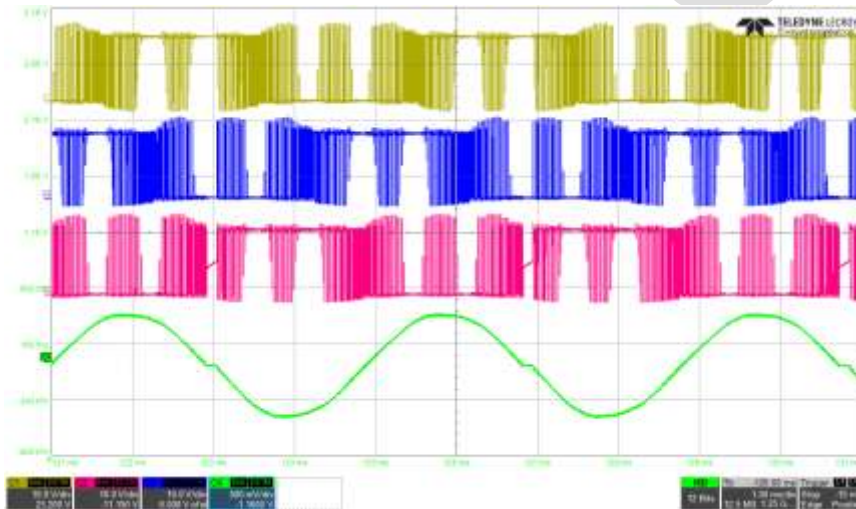

Ch1 : Uo , Ch2 : Wo , Ch3 : Vo , Ch4 : Iwo (FR pin = Floating or Low)

Function Descriptions

5VREG Current Set Up table

The current of 5VREG (I_{5VREG}) pin is used to select different CMD modes. It can set up function following the table.

5VREG to GND R	Over 15k ohm (Mode1)	2.7k ~ 6.8k ohm (Mode2)	Under 1k ohm (Mode3)
CMD mode	Pull High Current 200 μ A	Pull High Current 20 μ A Switch SS pin to YP2 SS fix 4 Sec	VSP Mode

AS Function Setup

The AS pin is used to set start up function. It can choose 8 align speed to start up the motor.

Step	V _{AS} (V) Min ~ Max (TYP)	Align Speed (rpm)		
		Mode1	Mode2	Mode3
	>4.85	960	576	384
241 ~ 255	4.265 ~ 4.500 (TYP=4.38)	192		
226 ~ 240	4.030 ~ 4.265 (TYP=4.15)	384		
211 ~ 225	3.795 ~ 4.030 (TYP=3.91)	576		
196 ~ 210	3.560 ~ 3.795 (TYP=3.68)	768		
181 ~ 195	3.325 ~ 3.560 (TYP=3.44)	960		
166 ~ 180	3.090 ~ 3.325 (TYP=3.21)	1152		
151 ~ 165	2.855 ~ 3.090 (TYP=2.97)	1344		
136 ~ 150	2.620 ~ 2.855 (TYP=2.74)	1536		
Forbidden				
105 ~ 119	2.145 ~ 2.380 (TYP=2.26)	1536		
90 ~ 104	1.910 ~ 2.145 (TYP=2.03)	1344		
75 ~ 89	1.675 ~ 1.910 (TYP=1.79)	1152		
60 ~ 74	1.440 ~ 1.675 (TYP=1.56)	960		
45 ~ 59	1.205 ~ 1.440 (TYP=1.32)	768		
30 ~ 44	0.970 ~ 1.205 (TYP=1.09)	576		
15 ~ 29	0.735 ~ 0.970 (TYP=0.85)	384		
0 ~ 14	0.500 ~ 0.735(TYP=0.62)	192		
	<0.15	960	576	384

Note : Align speed with +/-20% tolerance

SS Function Setup

The SS pin is used to set output duty change time. It defines 0.5s ~ 8s (Output Duty 0%~100%) change time linearly between 0.5V ~ 2.38V and 2.62V ~ 4.5V .

Step	Vss (V)	Duty Change Time (S)	
		Mode1	Mode3
	>4.85	0.5	8
255	4.5	0.5	
136	2.62	8	
Forbidden			
119	2.38	8	
0	0.5	0.5	
	<0.15	0.5	8

Soft Start time with +/-20% tolerance

YP2 Function Setup

The YP2 pin is controls the turning point of output 100% input duty at speed curve . It defines 53.2% ~ 100% output linearly between 0.5V ~ 2.38V and 2.62V ~ 4.5V .

Step	V _{Yp2} (V)	Duty Output (%)
	>4.85	100
255	4.5	100
136	2.62	53.2
Forbidden		
119	2.38	53.2
0	0.5	100
	<0.15	100

YP2 Duty out with 1/512 % tolerance

SO SEL Table

The M8321 supports FG、4/8 FG、4/12 FG and 4/10 FG outputs.

Mode 1

	AS > 2.5V	AS < 2.5V
SS > 2.5V	FG	4/12 FG
SS < 2.5V	4/10 FG	4/8 FG

Mode 2

	AS > 2.5V	AS < 2.5V
YP2 > 2.5V	FG	RD
YP2 < 2.5V	4/10 FG	4/8 FG

Current Limit

The M8321 includes internal current limit. It will turn off high side PMOS when output driver current is over 1.5A. The high side PMOS will turn on at next PWM cycle, and reduce the output duty. The M8321 also includes over current protection (OCP). If the output driver current is over 2.25A, all output MOS will turn off and enable lock protection. Chip will restart when lock off time is count down.

Lock Protection and Automatic Restart

The M8321 provides the lockup protection and automatic restart function for preventing the motor coil burns out. Since the M8321 starts up the motor by the sine wave pattern. The on time (T_{ON}) is defined by align speed option. If the motor cannot start up successfully, all driver MOSFETs are turned off and auto restart after the recovery time (T_{OFF}). The first recovery time is 1s and the others are 5s.

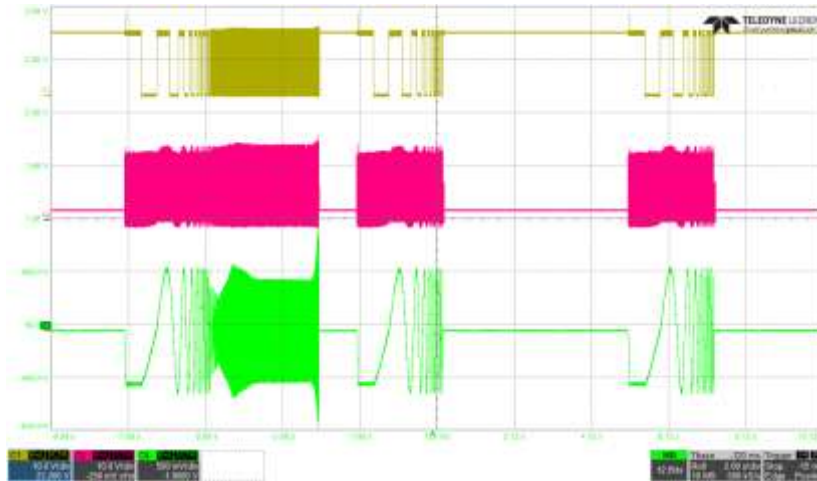

Ch1 : FG , Ch2 : Wo , Ch3 : Iw

Lock On time table

AS Speed (RPM)	FG (Sec)	4/8FG (Sec)	4/10FG (Sec)	4/12FG (Sec)
1536	0.94	1.04	1.08	1.1
1344	1.06	1.17	1.21	1.24
1152	1.22	1.35	1.39	1.43
960	1.43	1.6	1.65	1.7
768	1.77	1.97	2.03	2.09
576	2.31	2.58	2.67	2.75
384	3.41	3.82	3.97	4.06
192	6.71	7.53	7.79	8.02

Note : Lock On time with +/-20% tolerance

Quick Start and Standby Mode

When the input PWM duty of CMD pin is below 8% duty with shutdown function, the lock protection signal will be disable. Chip all circuit still work except driver MOSFETs turned off, and wait for quick start by the control signal. The M8321 also has standby mode enabled by the control signal under low duty (<0.5%) over a fixed time (16ms). In the standby mode, it will turn off all driver MOSFETs, internal clock and SO function, and the quiescent current is under 400 μ A.

I/O Equivalence Circuit

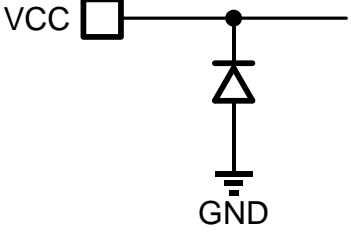
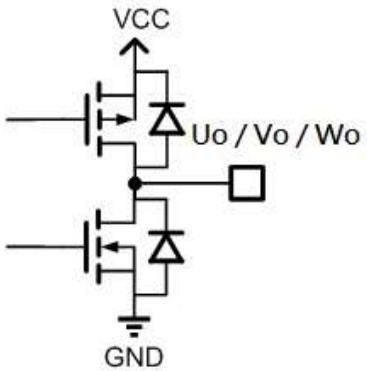
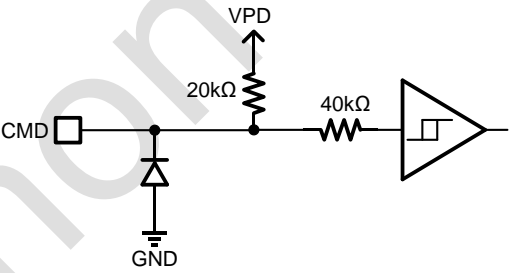
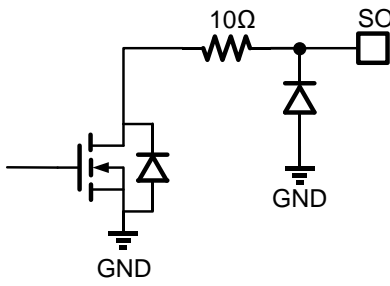
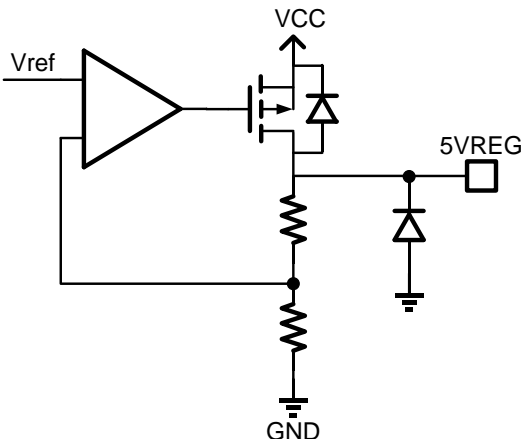
PIN	I/O	Equivalence Circuit
Power supply (VCC / GND)	Input	
Uo / Vo / Wo	Output	
CMD	Input	
SO	Output	
5Vreg	Input	

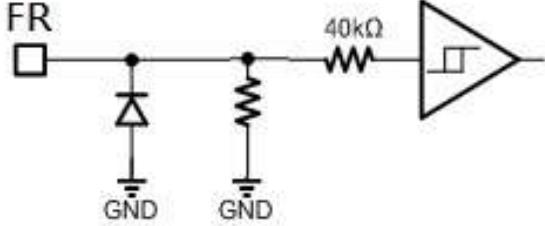
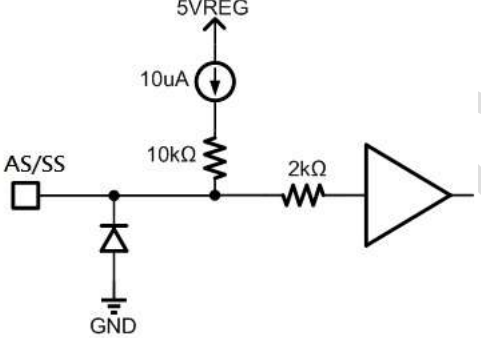
FR	Input	
AS/SS	Input	

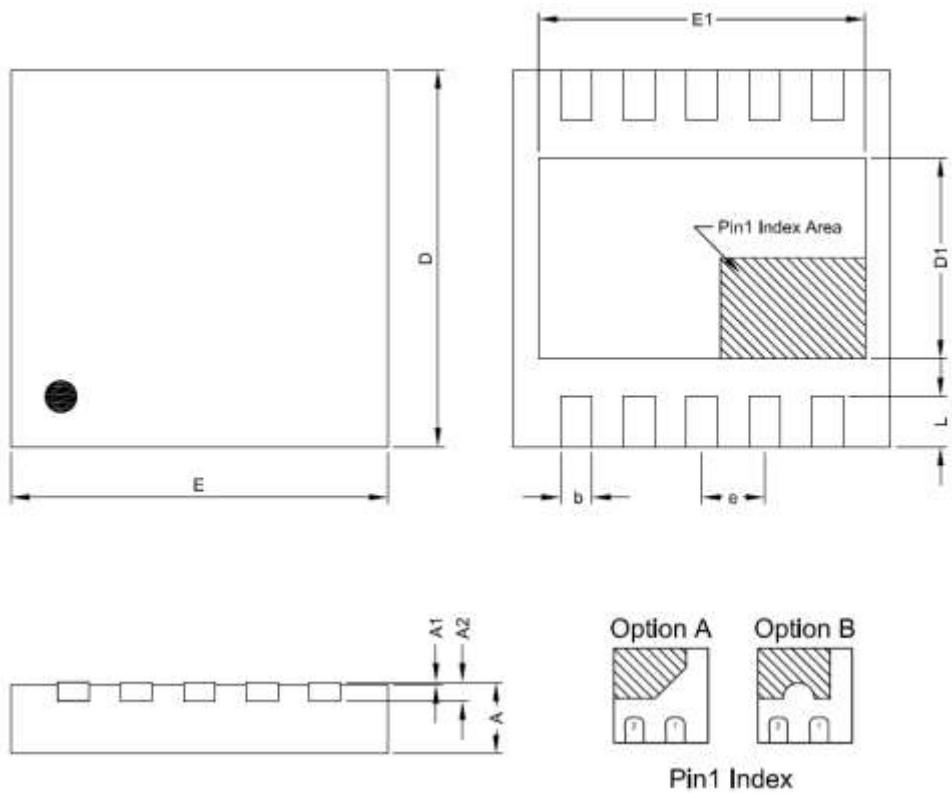
Package Information

WDFN3X3-10 Package

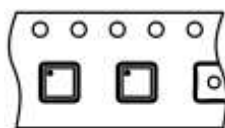
Symbol	DIMENSION IN MM			DIMENSION IN INCH		
	MIN.	NOM.	MAX.	MIN.	NOM.	MAX.
A	0.50	0.55	0.60	0.0197	0.0217	0.0236
A1	0.00	---	0.05	0.0000	---	0.0020
A2	0.15 REF			0.0059 REF		
D	2.95	3.00	3.05	0.1161	0.1181	0.1201
E	2.95	3.00	3.05	0.1161	0.1181	0.1201
D1	1.40	1.60	1.70	0.0551	0.0630	0.0669
E1	2.40	2.60	2.70	0.0945	0.1024	0.1063
b	0.18	0.25	0.30	0.0071	0.0098	0.0118
e	0.50 BSC			0.0197 BSC		
L	0.30	0.40	0.50	0.0118	0.0157	0.0197

Taping Specification

Feed Direction

PACKAGE	Q'TY/BY REEL
WDFN3X3-10	3,000 ea

GMT Inc. does not assume any responsibility for use of any circuitry described, no circuit patent licenses are implied and GMT Inc. reserves the right at any time without notice to change said circuitry and specifications.