

SPECIFICATION

MODEL : SH-82A (Forward Taping)

P/N : HE82A*1U12 (* : Rank)

Halogen Free

HALL ELEMENT

Tianjin Nanotech Electronics Co.,Ltd

**C8-2, International Industrial City XEDA,
Tianjin, China**

1. Application

This specification sheet is applied to Hall sensor that NANOS supplies.

2. Electrical Characteristics

2.1 Maximum Ratings

[Ta=25°C]

Parameter	Symbol	Rating	Unit
Maximum Input Current	I _{max}	20 (at 25°C)	mA
Operating Temperature Range	T _{op}	-40 ~ +120	°C
Storage Temperature Range	T _{st}	-40 ~ +150	°C

2.2 General electrical specifications

[Ta=25°C]

Parameter	Symbol	Conditions	Min	Max	Unit
Output Hall Voltage	V _h	V _{in} = 1V, B = 50mT	196	320	mV
Input Resistance	R _{in}	I = 0.1mA	240	550	Ω
Output Resistance	R _{out}	I = 0.1mA	240	550	Ω
Offset Voltage	V _o	V _{in} = 1V, B = 0mT	-7	+7	mV
Temp. Coeff. Of V _h	α	T _a =0 ~ +40°C	-	-1.8	%/°C
Temp. Coeff. Of R _{in} , R _{out}	β	T _a =0 ~ +40°C	-	-1.8	%/°C

※ V_h = V_{hm} - V_o (V_{hm} : The output voltage measured at 50mT)

2.3 Rank Classification and Mark on Output Hall Voltage

Output Hall Voltage V _h (mV)	Rank	Mark	Measurement Conditions
196 ~ 236	D	• D	V _{in} -1V, B=50mT (Constant Voltage)
228 ~ 274	E	• E	
266 ~ 320	F	• F	

3. Method for Mounting

3.1 Lead Frame

- 1) The material of lead frame is phosphor bronze alloy and the die bonded surface is plated by silver. The minimum thickness of plating is 3.0 μm .
- 2) Lead Frame is plated by pure Sn and the thickness is controlled by 4~12 μm .

3.2 Soldering Conditions on PCB

- 1) No rapid heating and cooling is desired.
- 2) Preheating is recommended for 1 ~ 2minutes at 150 ~ 190 $^{\circ}\text{C}$.
- 3) Reflowing is recommended for 10 ~ 20seconds at 220 ~ 260 $^{\circ}\text{C}$.

3.3 Soldering Method and Temperature

Items	Methods	Temperature
Reflow	Soldering by passing the heated zone	Max 260 $^{\circ}\text{C}$ in 10sec
Solder Iron	Soldering by solder-iron	Max 350 $^{\circ}\text{C}$ in 3sec

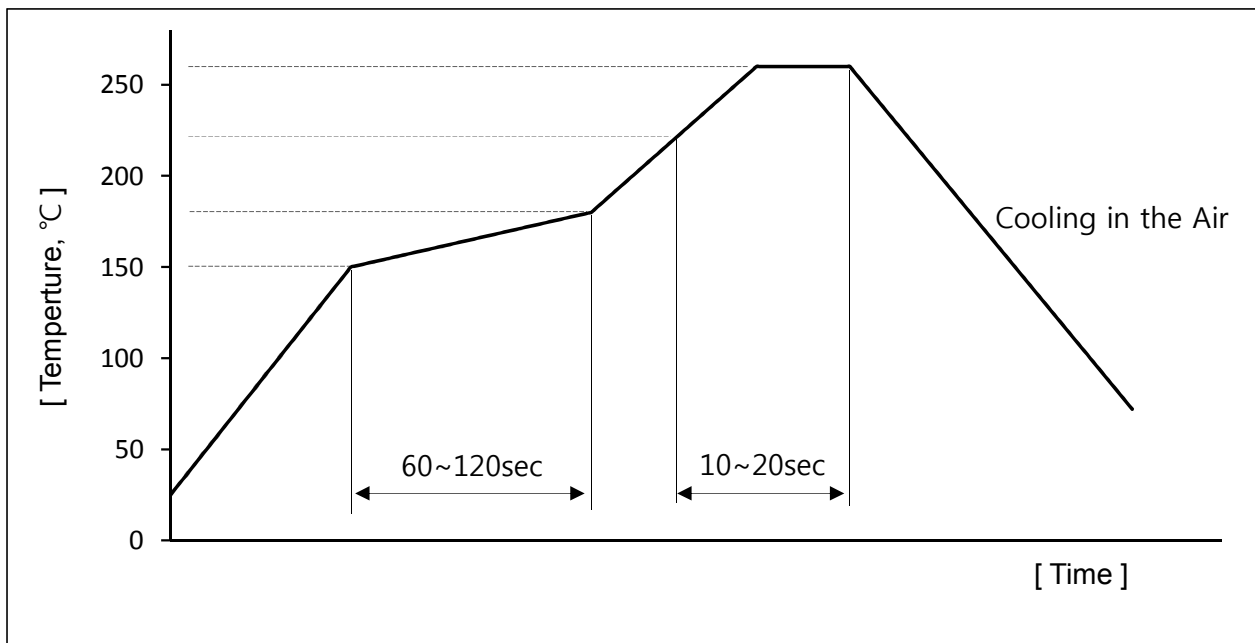

[Reflow Method]

4. Packaging

4.1 Taping

- 1) SH-82A(Forward taping) should be packed marking side to cover tape side and put long side to running direction. 180° rotation has no effect on the application.
- 2) At least, 40mm vacant parts are made both front and rear side of tape.

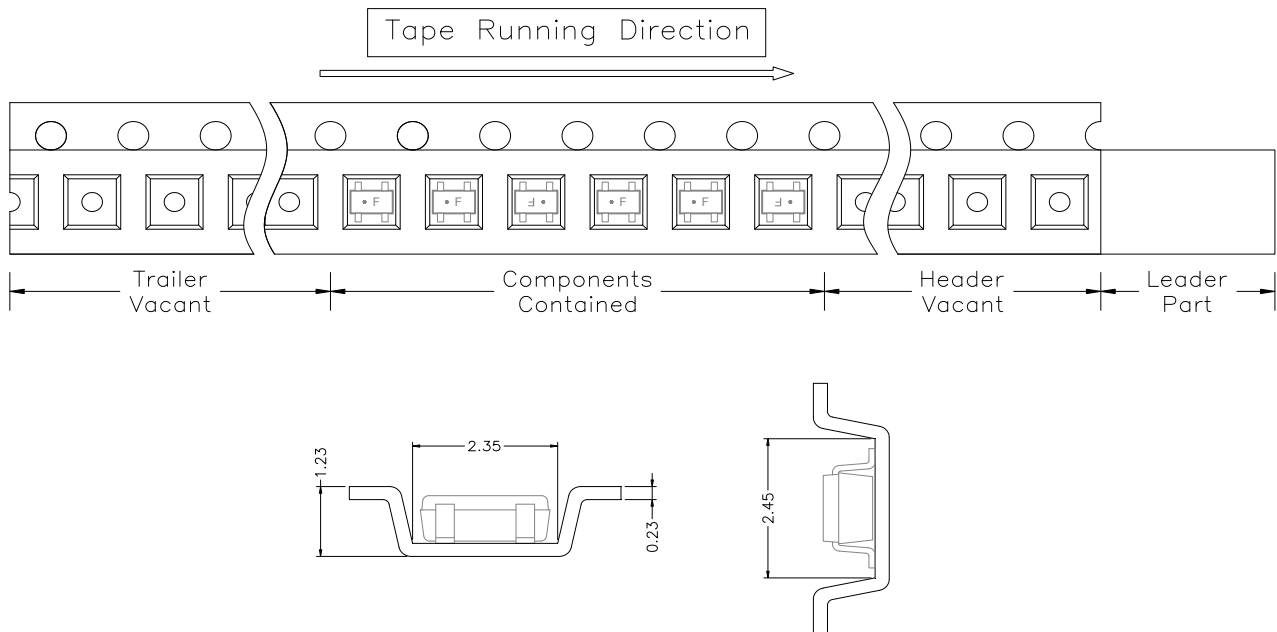

4.2 Handling Methods of Tape

- 1) Pull Strength(F) = 20 ~ 70g

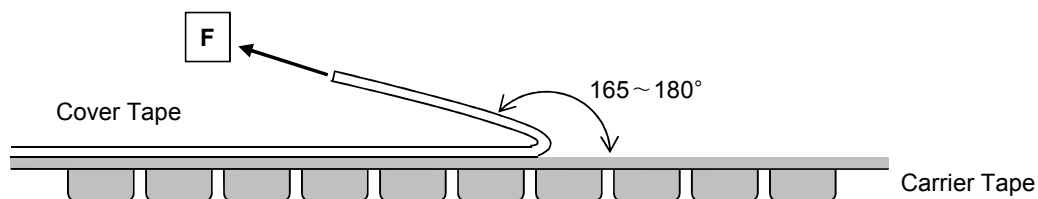

- 2) Devices should not run out of a pocket when tape is bent down 15mm curvature.
- 3) Devices should not stick to cover tape.
- 4) Devices should be kept below 40°C and below RH80% in the shade.
- 5) Tape has no joint

4.3 Packing Unit

- 1) 4,000pcs of devices are packed in one reel.
- 2) Five reels are packed in one inner box.
- 3) Four inner boxes, 80,000pcs of devices, are packed in one outer box.
- 4) Dummy could be packed for safe dealing.

5. External Dimensions and Appearance

5.1 External Dimensions (Unit : mm)

Four leads of input-output terminals are designed in the diagonally symmetric mode and are equal in dimensions. SH-82A(Forward taping) could be used without considering on the rotation of 180°.

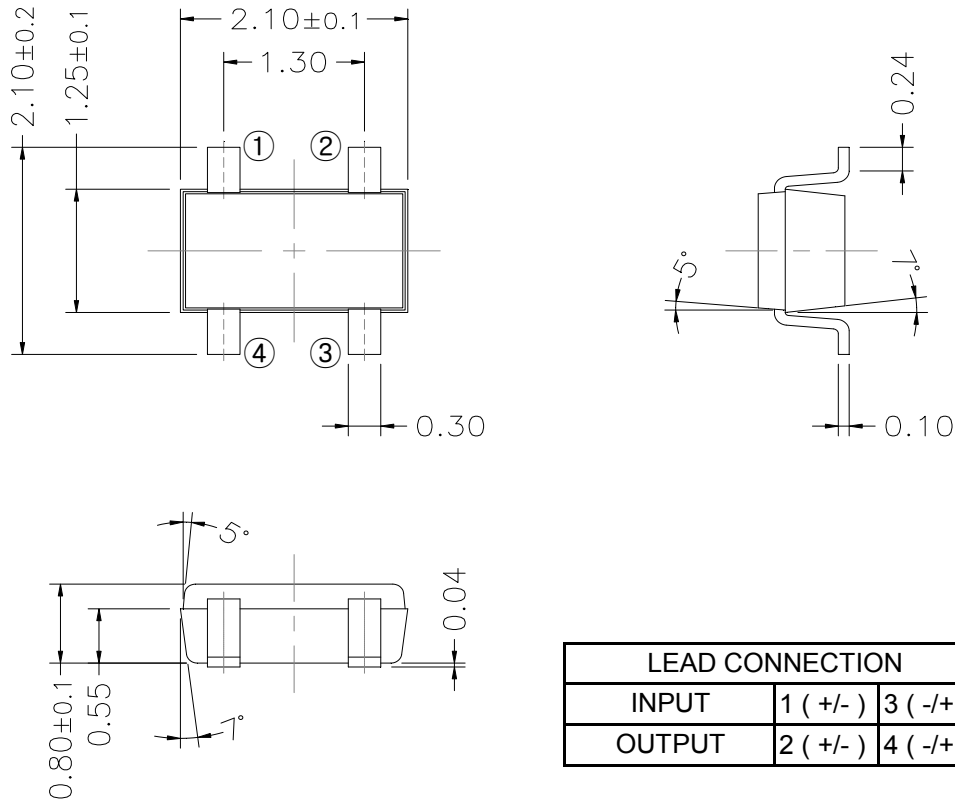

[Package Dimensions]

5.2 Marking Method

Devices should be marked by LASER beam in the form of 「• + 'Rank'」

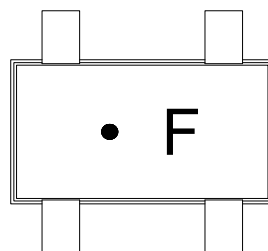

[F Rank]

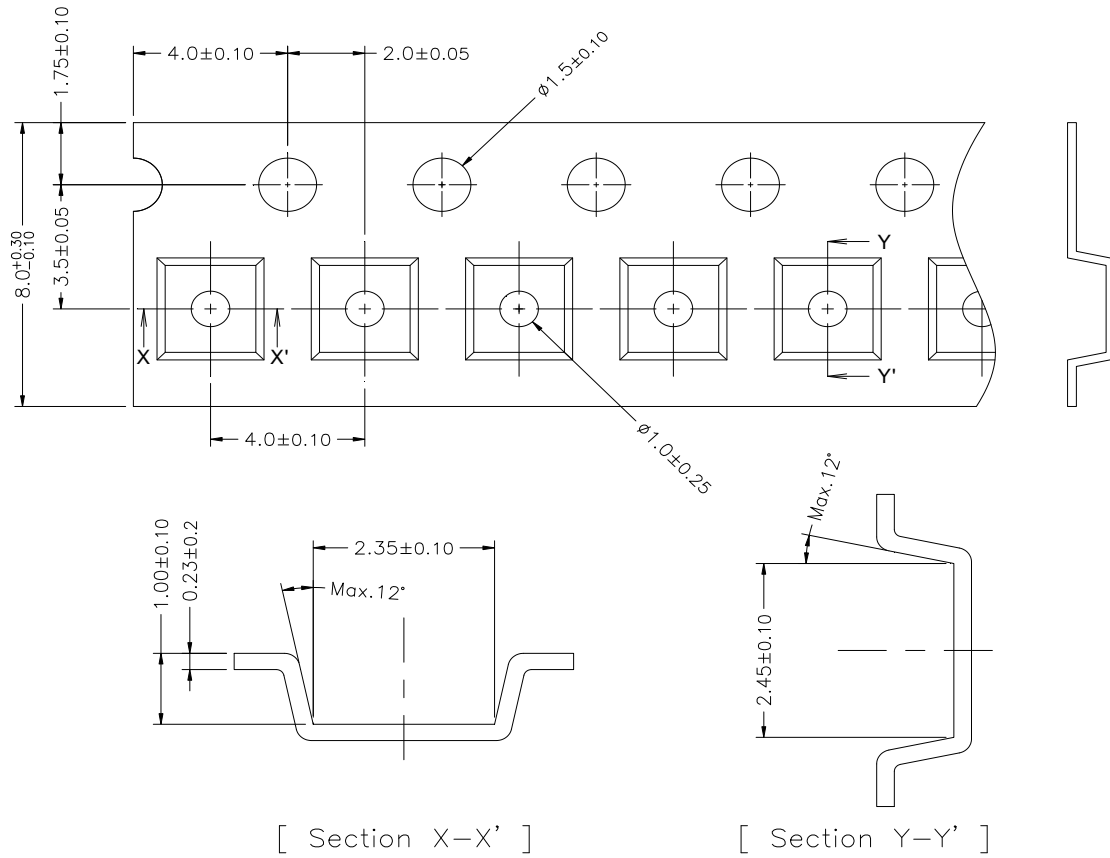
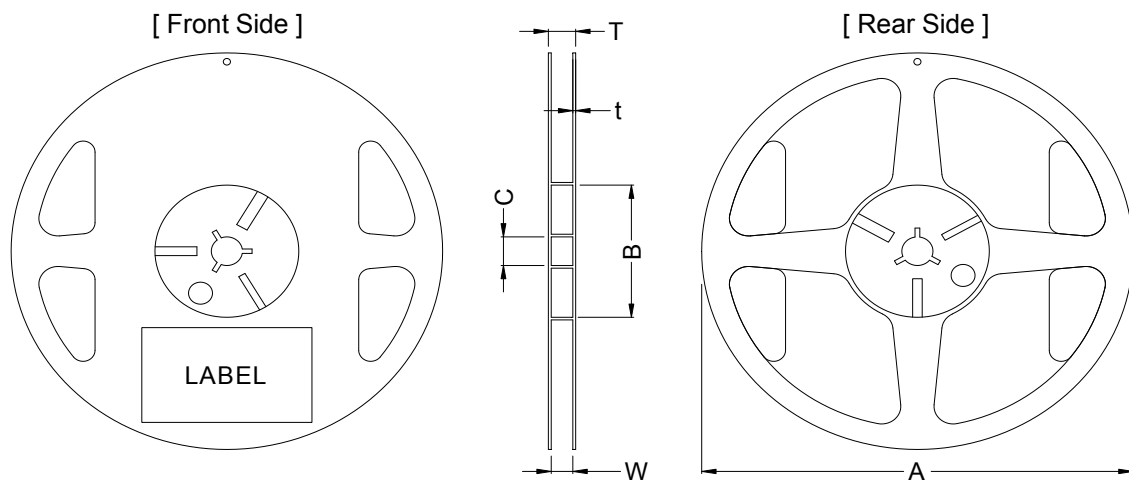
5.3 External Dimensions of Carrier Tape (Unit:mm)

5.4 External Dimensions of Reel (Unit:mm)

[Unit : mm]

Symbol	A	B	C	W	T	t
Spec.	$\phi 180 \begin{smallmatrix} +0 \\ -3 \end{smallmatrix}$	$\phi 60 \begin{smallmatrix} +1 \\ -0 \end{smallmatrix}$	$\phi 13 \pm 0.3$	9 ± 0.3	11.4 ± 1.0	2.0 max.

※ The above reel is made of plastic and is recyclable.

5.5 Reel Packing Structure

■ Example

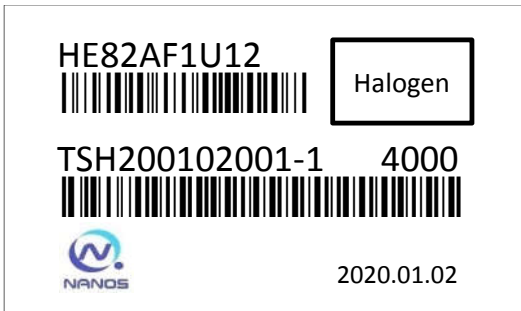

Manufacturing Lot Number

Halogen Free Label



1 Reel : 4,000 EA



Dry Pack.



1 Inner Box : 20,000 EA

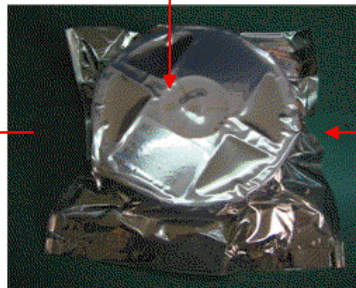

Vacuum Packing



5 Reel

Inspection Sheet



Outer Box : 80,000 EA



Packing Finished

6. Reliability

6.1 Test Item and Condition

No.	Test Item	Test condition
1	High Temp. Storage	Ta = 150 °C, t = 1000hr
2	High Temp. Operation	Ta = 120 °C, Iopr = 10mA, t = 1000hr
3	Low Temp. Operation	Ta = -40 °C, Iopr = 6mA, t = 1000hr
4	High Temp. High Humidity Operation	Ta = 85 °C, HR = 85%, Iopr = 9mA, t = 1000hr
5	PCT	Ta = 121 °C, HR = 100%, Pv = 2atm, t = 24hr
6	Thermal Shock	T(L) = -55 °C, T(H) = 150 °C, t(L,H) = 30min, M = 30cycle
7	High Humidity Temperature Cycle	T(L) = -20 °C, T(H)= 85 °C, t(L,H) = 30min, HR = 95%, M = 40Cycle
8	Soldering Heat Resistance	Peak Temp = 260 °C, t = 10sec, Reflow
9	ESD(MM)	V = 500V, C = 200pF, R = 0Ω(EIAJ Test Condition)

6.2 Criterion For Judging

After each reliability test, samples should be during at least 24 hrs in room emp. & humidity, and then measure. The change rates should be in the values as below.

Item	OK Spec	NG / OK
Rin	Under Initial $\pm 20\%$	OK (Spec. Satisfying)
Rout		
Vh		
Vo	Max. $\pm 5\%$	

* Vo change ratio calculation method

$$\text{Vo change ratio} = (\text{Vo-after} - \text{Vo-before}) / \text{VH-before} \times 100\%$$

7. Caution on treating

On surface mounting, please keep the statements written by mounting conditions.

Safekeeping Period is 6 month at room temperature in condition of being packed

8. The Analysis of RoHS(Restriction of Hazardous Substances)

It is guaranteed that there are no RoHS materials in Hall Sensor by specific analysis results

- References : RoHs 10 Materials

- 1) Cadmium(Cd)
- 2) Lead(Pb)
- 3) Mercury(Hg)
- 4) Hexavalent Chromium(CrVI)
- 5) PBBs(Polybrominated Biphenyls)
- 6) PBDEs(Polybrominated Diphenyl Ethers)
- 7) DBP(Dibutyl phthalate)
- 8) BBP(Butyl benzyl phthalate)
- 9) DEHP(Bis(2-ethylhexyl) phthalate)
- 10) DIBP(Diisobutyl Phthalates)

9. Halogen Free

NANOS Hall sensor guarantees that it contains no Halogenated materials.

That is Halogen Free product and is confirmed by specific analysis results.

- References : Halogen Materials

- 1) Fluorine(F)
- 2) Chlorine(Cl)
- 3) Bromine(Br)
- 4) Iodine (I)

- Halogen- free limitation(unit: ppm)

Br : 900 ppm, Cl : 900 ppm, Br+Cl : 1,500 ppm